

MAGNETIC FILM &

**THE MAGAZINE OF HOME AND
PROFESSIONAL SOUND RECORDING**

TAPE RECORDING

**NEW TAPE TESTS
RECORDERS**

**RECORDING VOCALS
WITH PIANO**

**DON'T MISS
THAT PROGRAM!**

**GIVE YOUR SLIDES
A VOICE**

**NEW PRODUCT REPORT:
LIFETIME TAPE**

**BINAURAL SOUND WITH
TWO RECORDERS**

TAPE CLUB NEWS



Doris Day

APRIL 1954

35c

NEW **HOT-SLITTING** PROCESS

GIVES **audiotape** EXTRA STRENGTH

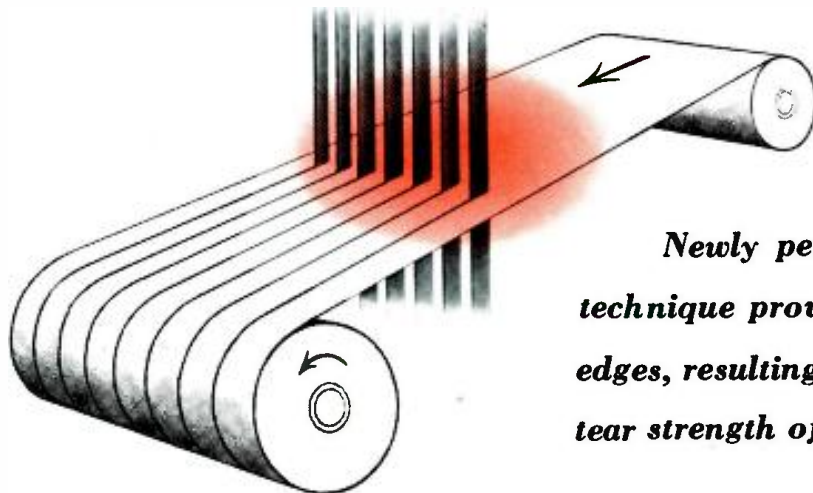

Newly perfected thermal-slitting technique provides smoother, cleaner edges, resulting in increased break and tear strength of plastic base Audiotape

IN THE manufacture of Audiotape, particular care has always been given to the slitting operation, in which the processed tape is cut into reel-size widths. Precision straight-line slitting has been one of the reasons why Audiotape tracks and winds perfectly flat and has no fuzzy edges to impair frequency response.

Now, however, even this superior slitting operation has been still further improved by precisely controlled heat application. The result, though not visible to the naked eye, is a significant increase in tape *strength*.

For thermal slitting avoids the formation of the microscopic cracks and irregularities which result, in varying degrees, from any cold slitting process. Each such defect is a source of weakness and a potential tape break.

The thermal treatment in no way alters Audiotape's *balanced performance*. Hence Audiotape not only offers you the most faithful reproduction of the original sound, but also assures the highest mechanical strength obtainable with cellulose acetate base material—all at *no extra cost*.



Audiotape is now available on this
NEW 7" PLASTIC REEL

- 2½ inch hub • more area for labeling • less chance of tape spillage • greater protection to tape • rugged, non-warping construction • distinctive, modern design

... and in colors, too!

Audiotape 7" reels can now be obtained, for special applications, in red, blue, green, yellow or clear plastic. And Audiotape is also being offered on either blue or green colored plastic base, in addition to standard red. These distinctively colored tapes offer interesting possibilities for specialized recording and filing applications. Write for further details.

AUDIO DEVICES, INC.

444 Madison Avenue,
New York 22, N. Y.

Export Dept., 13 East 40th St., New York 16, N. Y., Cables "ARLAB"

audiorecords • audiotape • audiofilm • audiopoints

of all recorders in the medium price field...

only **WEBCOR** **RECORDS IN** **BOTH DIRECTIONS**

(without bothersome reel turnover)

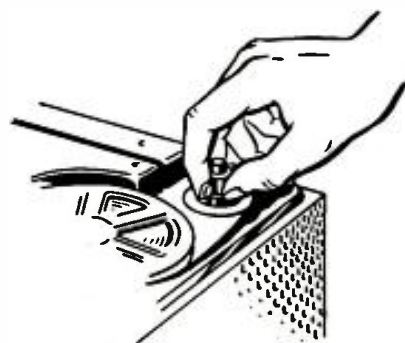

Simple, one-knob control gives split-second direction change without inconvenient reel turnover.

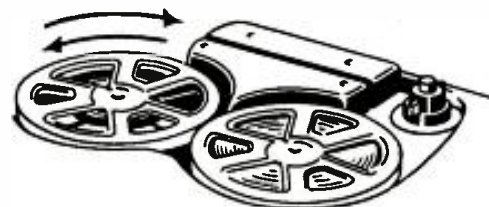

Two recording heads for recording in both directions.

You'll find a professional feature on your Webcor Tape Recorder that gives tremendous recording flexibility. Webcor's TWO high-fidelity recording heads and TWO constant-speed, 4-pole motors let you record in BOTH DIRECTIONS WITHOUT BOTHERSOME REEL TURNOVER. Only Webcor has this feature in the medium price field. With Webcor you needn't interrupt your symphony, opera, play or speech recording just because you come to the end of the reel. Simply flick the Webcor control knob and in a split-second you are recording in the opposite direction up to TWO FULL HOURS ON THE SAME REEL.

This outstanding feature is yours...at no additional cost. Shop and compare. See why over 40% of all Tape Recorders sold during 1952 were Webcor! Only \$207.50.*

The Webcor Tape Recorder records at 3¾ and 7½ ips. Frequency response at 7½ ips up to 10,000 cycles. Webcor Magic EYE recording level insures professional quality recordings right away. Wow and Flutter less than .5%. Special input for recording direct from radio, TV or phonograph. Output welcomes replay through external amplifier or speaker.

**prices slightly higher West and subject to change without notice.*

Webcor®

Webcor is the trade name of the Webster-Chicago Corp., Chicago 39



Vol. 1 No. 2

So many of you folk have so generously responded to the words in this space last issue and to the review of some of the tapes, and the article on how Multee-Trak recording is done, that I'm a bit behind in keeping up with correspondence. So I'll make this a blanket apology to those good readers who haven't heard from me, and promise to catch up soon.

But to be honest, those wonderful orders for pre-recorded Home Library 7 1/2 IPS full track tapes, each accompanied with a check for \$9.85, get first call. You know I make a special dedication on each tape addressed to the person to whom it goes. That's something added to the high quality of reproduction a person can't get when they drop into a store and buy a now superseded platter!

You've probably read the reviews on my full-half-hour-of-music tapes TR 501, TR 504 and TR 505. You can order them on a safe "you must be completely satisfied or your money back instanter" basis. \$9.85 each, postpaid. Absolutely FREE—a full list of all tapes available will come to you upon request. A postcard will do. Just address it to Department TR, P.O. Box 2384, Sarasota, Florida.

Several people have inquired whether or not we are going to appoint retail dealers to sell our tapes. The answer is "yes—eventually" (if dealers write me) but continue ordering direct please until your dealer can supply you.

It's nice to chat with you. Thanks for reading. And if you have any questions, drop me a line and I'll try to answer fairly soon.

Thanks for reading!
Yours—

Hack

In Sarasota, Entertainment Capital of Florida, are the modern studios of Hack Swain Productions where northern producers and talent come to combine recreation in the Gulf Coast's finest weather with unexcelled recording and motion picture film facilities. They find they do it BETTER in Sarasota!



MAGNETIC FILM &

TAPE RECORDING

VOL. 1 NO. 3

MARCH-APRIL, 1954

MARK MOONEY, JR.
Editor and Publisher

MILDRED STAGG,
New York Editor

JOHN L. ALLEN,
Circulation Manager

GEORGE M. THOMPSON,
Technical Consultant

JAMES H. MILLS, SR.,
Technical Consultant

ROBERT W. LAPHAM, *Art Director*

IN THIS ISSUE

RECORDING VOCALS WITH PIANO	L. L. Farkas	16
GIVE YOUR SLIDES A VOICE	C. M. Waite	22
DON'T MISS THAT PROGRAM	Lou Burdick	26
NEW PRODUCT REPORTSOUNDCRAFT LIFETIME TAPE		29
SOUND EFFECT: WATER	Bart Pierson	30
TAPE CLUB NEWS		31
BINAURAL SOUND WITH TWO RECORDERS	Ronald Anderson	32
NON-SKID TIRE FOR MICROPHONES	Karl A. Barleben	37
RECORDER MAINTENANCE WITH A NEW TAPE	Harold E. Weiler	38
RECORDER SERVES AS PHOTO TIMER	Clarence Leino	41
NEW TAPES	Charles D. Sigsbee	6
NEW PRODUCTS		8
QUESTIONS AND ANSWERS		13
TAPES TO THE EDITOR		14

Cover—Doris Day, CBS Radio photo

Magnetic Film & TAPE RECORDING is published bi-monthly by Mooney-Rowan Publications, Inc., Severna Park, Md. (Severna Park 548). Application for entry as second class matter at the Postoffice in Severna Park, Md. is pending. Eastern Advertising Representatives: J-V Associates, 274 Madison Ave., New York 16, N. Y. (OREgon 9-0030). Midwestern Representatives: Cole and Mason, 605 N. Michigan Ave., Chicago 11, Ill. (SUPERior 7-6558). Pacific Coast Representatives: Brand and Brand, 1052 W. Sixth St., Los Angeles 17, Cal. (Michigan 1732). Subscriptions, U. S. and Possessions, Mexico, Central and South America. \$2.00 for six issues, Canada add \$.25 a year; all others add \$.50 a year. Contents copyrighted by Mooney-Rowan Publications, Inc., 1954. Printed in U. S. A.

THE COVER CELEBRITY

We tip our hat this issue to Doris Day, bright-eyed singing star who was the girl back home to thousands of G.I.'s during the Korean war. Her CBS show was rebroadcast to the troops overseas and the boys sent her an average of 300 letters a week. Among the honorary titles they bestowed on her are: "The Girl We'd Most Like to be Rotated With," "The Girl We Would Like to Take a Slow Boat Back to the States With," "The Doris We Would Most Like to Spend the Day With," "The Girl with the Voice that Could Melt the Iron Curtain," and from a fire-fighting group, "The Flame We Would Never Extinguish."



Doris Day

She was a soloist with Bob Crosby and Fred Waring and is one of Columbia Record's stars. Her albums of records from her pictures have been enormous hits and she has been on the best seller lists. On her birthday in 1951 she married her radio show producer, Marty Melcher (sorry boys).

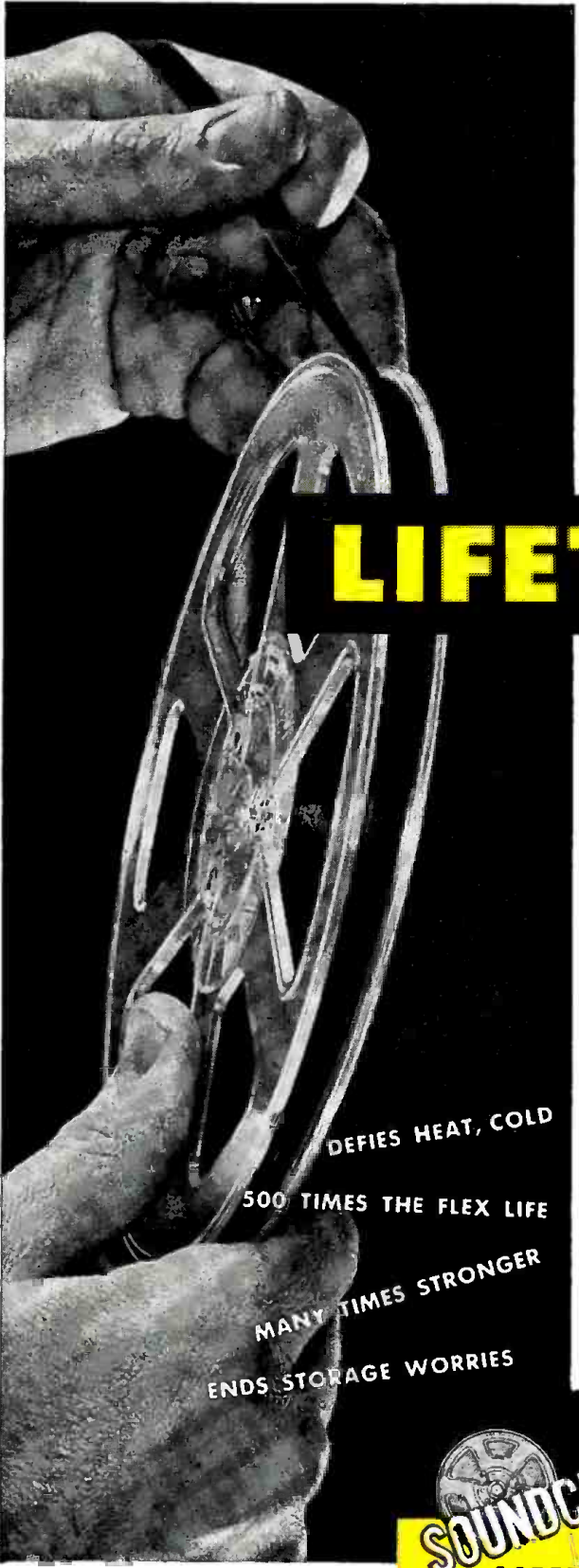

NOW Soundcraft
brings you
tape perfection!

the revolutionary new

LIFETIME[®] magnetic recording tape

Here is news of monumental importance to every recording perfectionist. It is the all new Soundcraft LIFETIME Tape. We've called this amazing high-fidelity tape "LIFETIME" because . . .

It will last, to the best of engineering knowledge, forever!

Your recording machine will never break it. Neither will careless handling. Because LIFETIME Tape is fully a third as strong as machine steel. It ends tape shrinkage and stretch when your home or studio air is dry or humid. It will never cup or curl. You can forget about storage problems.

All this means that for the first time you can preserve your important recordings, capture and keep those precious moments of music and the spoken word, for generations to come—in all their original fidelity!

LIFETIME Tape owes these new and permanent qualities to its new magnetic oxide coating, and to its base of DuPont "Mylar" polyester film. For both are free of plasticizers whose gradual loss from ordinary tapes limits their useful life.

LIFETIME Tape is indeed the biggest development in tape since the tape recorder itself. Your serious recordings deserve it. Order LIFETIME Tape today.

DEFIES HEAT, COLD
500 TIMES THE FLEX LIFE
MANY TIMES STRONGER
ENDS STORAGE WORRIES

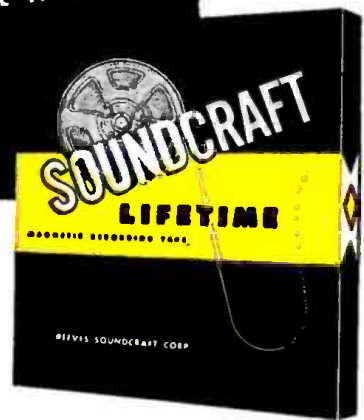

Like all Soundcraft magnetic products, LIFETIME Tape is Micro-Polished[®], assuring maximum high-frequency response. It provides uniformity of $\pm\frac{1}{4}$ db. within a reel, and $\pm\frac{1}{2}$ db. reel-to-reel. It is splice-free in 600-, 1200- and 2400-foot reels.

REEVES
SOUNDSCRAFT
CORP. Dept. S3
10 East 52nd Street, New York 22, N.Y.

PENTRON... first with 2 speeds now offers another first... new, sensational

PENTRON 3-SPEAKER TAPE RECORDER

opens a whole new world of high fidelity sound.



Model HT-225
Complete \$225

NOW...

Unique Mobile Speaker Adds New Dimension to Sound!

Pentron offers music lovers a new listening thrill—the first tape recorder that achieves true stereophonic sound. Pentron features a separate “roving speaker,” with individual volume control, for reproducing high notes.

Mounted in the lid, this third speaker can be placed anywhere in the room for unmatched musical realism and sparkling voice playback. It supplements the two internal, heavy-duty matched speakers which give amazing life and beauty to middle and bass tones.

Pentron alone offers a complete LC crossover network in a tape recorder so low in price—so rich in performance.

Learn how Pentron's 3-Speaker Tape Recorder adds new Dimension to Sound.

THE PENTRON CORP.
CHICAGO 16, ILLINOIS

mail coupon NOW!

The Pentron Corp., Dept. MF3
221 E. Cullerton St., Chicago 16, Ill.

Rush, without obligation, free literature on new 3-Speaker Tape Recorder with “roving speaker.”

Name _____
Address _____
City _____ Zone _____ State _____

NEW TAPES

THE Society of Tape Boosters (unorganized) picked up a new, and illustrious, member recently.

Leopold Stokowski, in a recent St. Louis interview, told a *Post-Dispatch* reporter, “Tape has a better quality of sound, and there is the fact that the tape is cut to the music, not the music to the disc. There is no need for adjusting the length of the music to the length of the medium when using tape.”

He further said that, “It is high time that tape-recordings were made available commercially, in lieu of disc-recordings.”

These are weighty words. Not only because they were spoken by an eminent conductor, one of the truly great figures in American music, but also by one of the pioneers in high-fidelity music reproduction.

It was Stokowski who not only created, in the Philadelphia Orchestra, what many consider to be the world's finest musical aggregation, but talked the RCA engineers into turning out some extremely creditable high-fidelity recordings of the organization back in the middle '30's. (At least one collector I know still insists that these early attempts sound better than anything he has on LP!)

It was also Stoky who conducted, with Bell Laboratories, the long-remembered and still much discussed stereophonic demonstration before a group of scientists assembled in Washington's Constitution Hall. Like the current “Cinerama,” it was an emotional as well as musical experience.

The orchestra was in Philadelphia behind a battery of microphones lining the stage of The Academy of Music. Each microphone was attached to its own telephone line, at the other end of which was a separate speaker system consisting of Western Electric 594, high-frequency drivers and specially constructed woofers. These, of course, lined the stage of Constitution Hall, each in the same relative position as its companion mike in Philadelphia.

The orchestra was conducted by an assistant, as Stokowski was in Washington conducting the great audio console, not trusting, apparently, the musical aptitude of Bell Lab's engineering staff! He understands electrons almost as well as music.

Nor was this his only experiment with high-fidelity, stereophonic music reproduction: Remember “Fantasia”? That was a Stokowski venture, in league with Walt Disney, and I'll bet that a reissue of it right now would pack theaters in the major cities.

With all of this pioneering background, both electronic and musical, this gentleman is not just riding his gain. The sounds he makes have considerable influence in the right circles and could be the sparks to fire the revolution.

Another, and even more widely read, boost appeared in the February issue of *The Atlantic*, and one I recommend to the readers of this column. Written by, the also eminent, editor of *High Fidelity* magazine, and regular contributor to *The Atlantic*, John Conly, the article reviews the work

being done to increase the quality of tapes and tape recorders, at the same time lowering the cost. The piece ends with these prophetic words:

“There are people, not given to loose talk, who say that the days of the classical phonograph disk are numbered. None of them care to pick a number, but there is reason to think that they are right.”

Of particular interest to this column is his revelation that Westminster plans to enter the tape field this year (including those magnificent Scherchen recordings?), and the rumor that Columbia may try tape, at least experimentally. If Columbia doesn't quite know where to begin I suggest Berlioz' “Symphonie Fantastique,” by Ormandy and the Philadelphia Orchestra. I'll buy the first one.

Returning from the realm of probability, we note that another company, *Audiosphere, Inc.*, of Livingston, New Jersey, has entered the tape field with the promise of creating a sensation. They took their recorders to Florence, Italy and made binaural recordings in the Teatro Comunale of an orchestra under the direction of Vittorio Gui. Gui, like Stokowski, is as interested in the sound of the playback as he is in the live production. According to advance information no compromises were made, musically or technically.

I had hoped to have their tapes for review in this issue but apparently, like *Webster-Chicago* and *Pentron*, their initial output was delayed somewhat. If all of the tapes I am expecting to receive arrive, in the next few weeks, this column should blossom forth in the spring like a fully fertilized forsythia.

The tapes received this month were, as usual, excellent examples of the general superiority of tape over record. Also excellent examples of the fidelity that can now be achieved at the speed of 7½ IPS.

HACK SWAIN PRODUCTIONS Sarasota, Florida

Program #506—7½ IPS, Full Track

Anne Mundy, Concert Pianist

Organ Prelude — G Minor — Bach-Siloti (sic)

Romance, Opus 28—Schumann

Prelude in A Minor

Sarabande—Debussy

(from Suite “Pour le Piano”)

Primavera, Opus 39, No. 3—Medtner

Prelude, Opus 12

Concert Etude in D flat Major—Liszt

Ritual Fire Dance—DeFalla

Program #507—7½ IPS, Full Track

Anne Mundy, Concert Pianist

Prelude in A Minor—Arensky

Caprice Viennois—Kreutzer

Sonatine, 3 movements—Ravel

Moderate

Mouvement de Menuet

Anime

Fairy Tale, Opus 34, No. 2—Medtner

Liebestraum—Liszt

Prelude, Opus 28, No. 4—Chopin

Malaguena—Lecuona

AFTER YOU TAPE IT

Send your recorded business session, meeting or speech to "Mr. Transcript" who will give you a reporter-accurate verbatim typed record.

And Remember

If your meetings are worth holding they are worth recording and putting on paper. If you're around New York-New England, we'll record them for you.

Manuscripts, theses, reports and correspondence also transcribed, using tape at 3.75 or 7.50 and reels up to 7" or using Audograph, Edison, Dictaphone or SoundScriber discs or belts.

PROMPT MAIL SERVICE

CHARLES TRANSCRIPT SERVICE
154 Nassau Street New York 38
WOrth 4-1486

for IMMEDIATE DELIVERY



The New MT-1 PRESTO SPLICER

for

WELDING TOGETHER 1/4" acetate tapes without cement or adhesives...

- Diagonal cut capable of withstanding 3 pound pull
- Inaudible with playback amplifier gain at maximum

\$65 F.O.B. Factory

For Millar Tape, add \$2

Sample splice and brochure on request.

PRESTOSEAL MFG. CORP.

3727 33rd st., Long Island City 1, N. Y.

Best Recording Tape Buy!



1200 FT. REEL
Genuine Plastic Base
RECORDING TAPE

\$1.89 per roll plus postage
C.O.D. accepted

LAFAYETTE made a terrific deal with one of the leading manufacturers of recording tape to supply us with their regular tape which sells for almost twice our price. **WE GUARANTEE ABSOLUTE SATISFACTION OR YOUR MONEY BACK.** The finest, professional-quality recording tape obtainable. Highest performance for thousands of playings. Red Oxide Base in a smooth, uniform coating; greater signal strength; with maximum fidelity; uniform frequency response from 40-15,000 cps.

Write for free catalog.

**LAFAYETTE
RADIO**

DEPT. Y

NEW YORK, N.Y. 100 Sixth Ave.
BRONX, N.Y. 542 E. Fordham Rd.
NEWARK, N.J. 24 Central Ave.
PLAINFIELD, N.J. 139 West 2nd St.
BOSTON, MASS. 110 Federal St.

HAVE FUN AT YOUR NEXT PARTY

Tape record this old fashioned melodrama and play it back. Good for a hundred laughs. Five parts, three male, two female... and a donkey. Full directions for sound effects. Complete set of scripts (six copies) as presented on air only \$2.95 postpaid.

TAPE RECORDING Severna Park, Md.

NEW PRODUCTS

TWO CHANNEL RECORDER



Educational Laboratories, Inc., 1625 Connecticut Avenue, N.W., Washington 9, D. C., is marketing the Educorder Dual Model M-3, a two channel recorder. It has two separate record-play and erase heads and can play back the two channels simultaneously. It may be used for binaural recording or playback, or the two channels may be used separately so that a student can listen to pre-recorded material on one channel and use the other channel simultaneously for his own recording practice. A special provision permits easy use of the second channel for automatic control of slide or strip film projectors. Both 3 3/4 and 7 1/2 speed. 50 to 5,000 cycles at 3 3/4, 70 to 7,500 cycles at 7 1/2. Fast forward and re-wind, 43 Kc erase, may be operated in any position. Price \$343 F.O.B. Washington.

AMPEX CONTINUOUS PLAY



Ampex Electric Corporation, Redwood City, California, has introduced this continuous playback machine which will operate for eight hours without repeating. It may be used to furnish music for skating rinks, funeral parlors, restaurants, etc., or small radio stations may record their entire schedule in advance, freeing personnel for other duties or from long vigils.

The machine uses pre-recorded tapes running at 3 3/4 inches per second and has a uniform response up to 7,500 seconds which exceeds most present commercial installa-

tions. Another model is built to operate at 7 1/2 ips and up to 15,000 cycles. The latter model plays for four hours without repeating.

The machine, Model 450, uses a 14 inch reel holding 4,800 feet of tape. Reversal of the tape and the switch to the second track is accomplished by a sub-audible note which the tone detector hears to operate a relay.

MASCO 2 MOTOR 2 SPEED



The Mark Simpson Mfg. Co., 32-28 49th Street, Long Island City 3, N. Y., has announced the Masco Series 53 recorder. The recorder is equipped with two motors and has dual speeds of 3 3/4 and 7 1/2 ips. Frequency response is 80-8,500 cps plus or minus 3 db. at 7 1/2 ips and 80 to 5,000 at 3 3/4. Power output is 5 watts to internal or external speaker. The case is finished in maroon leatherette and reels store inside the lid. Press to record button prevents accidental erasure. Automatic amplifier equalization is provided for both speeds. Model 53R has a built-in radio. Full details and price by writing to the manufacturer.

MINI-MIX MIXER



Switchcraft, 1328 N. Halstead St., Chicago, 22, Illinois, is marketing the Mini-Mixer, an all metal, two channel mixer that measures about 2 x 1 3/4 x 1 inch. Hearing aid type controls mix the two inputs. It is small enough to be stored in the recorder case and is available with two types of input jacks, one for the standard phone jacks and the other for the standard microphone connectors. Lists at \$7.95.

(Continued on page 10)

Now Record it...



...the **Easy** way

with RCA'S New Push-Button Tape Recorder

Here's the new idea in recording that lets you record what you want, *the instant you want it*—the new RCA PUSH-BUTTON Tape Recorder. In one compact package, RCA combines the most faithful reproduction and the easiest operation ever offered in recording equipment priced so low.

Easy to Record—Just push a button and the RCA Tape Recorder is in action, making a faithful record of the sounds and voices you cherish.

Easy to Play—Just push a button, and you hear what you've recorded—*instantly*. Fast forward and reverse speeds are push-button

operated, too, so you can locate any portion of your tape recording easily.

Easiest to Use—RCA design makes the RCA Tape Recorder ready to go wherever you want it—easy to carry—no bigger than an overnight bag. Easy to thread—just drop the tape in a slot. Easy to record your favorite radio programs or speeches with handy, plug-in jack. Two-speed operation lets you put as much as two hours of recording on a single tape.

For your Home, Office, Plant, School, or Church—insist on the easy way to make tape recordings—the RCA PUSH-BUTTON Tape Recorder. Try it, buy it at your RCA Dealer's.

IF IT'S WORTH RECORDING, *it deserves the quality of RCA Sound Tape*



RADIO CORPORATION of AMERICA
ENGINEERING PRODUCTS DEPARTMENT CAMDEN, N.J.

The Magneraser*
Perfect Magnetic Tape Eraser



**100% Erasure Guaranteed
 WITHOUT REWINDING**

You no longer need a cumbersome and costly tape demagnetizer. The Magneraser* has all the features necessary for quick, efficient and absolute erasure of any recorded reel of tape. No matter what tape recorder you are using, or how severely the tape is overloaded, the Magneraser* is guaranteed to eliminate completely all recorded signal and bring the background noise level 3 to 6 db. below that of new unused tape.

You can carry the Magneraser* from room to room and use it wherever you have an AC outlet. To operate, simply place the Magneraser* on top of the reel of tape and move it once around. Within seconds, the complete reel is wiped perfectly clean.

Size 4" dia., 2 1/2" high; Weight 2 1/2 lbs.; Operating current 90 to 130 volts, 25 to 60 cycles; Power consumption 60 watts. Furnished with 8 ft. cord, molded rubber plug, and operating instructions. See your local dealer or write directly to factory. Net Price.....\$18.00

AMPLIFIER CORP. of AMERICA
 397 Broadway, N. Y. 13, N. Y.
7-C. Reg. U.S. Pat. Off.

NEW REEL AND COLOR TAPE



Color has been added to the tape recording field with the announcement by Audio Devices, 444 Madison Ave., New York 17, N. Y., of both colored reels and colored tape. The tape is available at a slightly higher price in both green and blue in addition to the regular brown. The colored plastic reels are at regular price. The company feels that colored tape will open up new fields of tape recording; lengths of colored tape spliced in the reels would indicate portions that should not be erased in language instruction. Recording and broadcast studios will find the colored tape reels gives added protection against accidental erasure and labeling errors, the company states.

The coloring of the tape has no effect whatever on its splicing capabilities which are the same as regular brown tape. In addition to its use in language instruction the colors will also be useful in music work, where, as in the language instruction, the student will record on the uncolored portion what he has listened to on the colored part.

PENTRON 3 SPEAKER



Pentron Corporation, 221 E. Cullerton St., Chicago 16, Ill., announces the Pentron 3 speaker recorder. Two of the speakers are woofers and are contained in the recorder case, the third (a tweeter for extreme highs) is mobile and may be placed anywhere in the room for a binaural effect. The recorder features an LC crossover network at 1000 cycles, push button speed change, a special editing key, and magic eye level indicator. Frequency range is 50 to 10,000 at 7 1/2 ips. The list price is \$225 complete with mike and tape. Write Pentron for full details.

WALKIE RECORDALL



Miles Reproducer Co., Inc., 812 Broadway, New York 3, N. Y., is marketing the Walkie-Recordall an 8 pound, self-powered recorder that also plays back. It may also be operated on 110 volt AC. The recorder uses a stylus to cut record grooves in a continuous belt. Priced from \$350 to \$785, depending upon model and accessories.

FREE SOUNDSTRIPING

Bell and Howell, Chicago, is offering to soundstripe 400 feet of 16 mm. film free if it is sent in through an authorized dealer. The film will be returned to the dealer who will assist the film owners in recording their own sound commentary. Offer is open to amateurs audio visual departments, etc. and is good only during February and March, 1954. Look in phone book for nearest dealer.

CRESTWOOD 303



Daystrom Electric Corporation, Poughkeepsie, N. Y., is manufacturing the Crestwood 303 which has the same tape transport mechanism as their hi-fi 400 model. Push button controls are used and the unit has a 6 x 9 oval speaker. Both 3 3/4 and 7 1/2 ips speeds are available and the machine has a fast forward and fast rewind. The power output is 10 watts and the frequency response is 50 to 10,000 cycles plus or minus 2 db. The 303 will accommodate a 7 inch reel. An external speaker may be connected by means of a jack provided. All connections are made on the back panel. A "tone touch" control system allows the user to select any of nine response characteristics. Full specifications and price may be had from Daystrom.

WEBCOR CLOCK RADIO

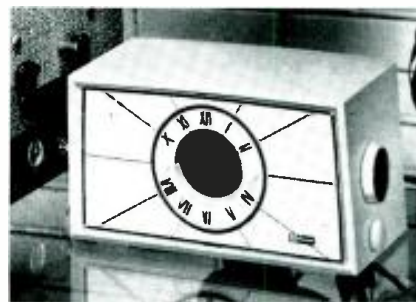

Webster-Chicago Corporation, 5610 W. Bloomingdale Avenue, Chicago 39, Ill., enters a new field with the introduction of the "Quinter" a five-purpose clock radio. It features a plug for attaching a tape recorder to make recordings of radio shows. A phono input permits playing records through the radio's amplifier, and the timing controls will turn on a recorder or other appliance up to 12 hours after it is set. The "slumber" control will turn off the radio and appliances such as a recorder, up to one hour after setting. List price is \$44.95.

SOUND EFFECTS CATALOG

Standard Radio, 360 N. Michigan Avenue, Chicago 1, Ill., has available a "Super Sound Effects" catalog listing hundreds of sound effects for dubbing on tape or for use on the air. Send 10 cents to the firm for the catalog.

ELECTRO-VOICE MIKE



Electro-Voice, Buchanan, Michigan, is the manufacturer of the Model 647 Lavalier Dynamic Microphone for chest, desk or hand use. Frequency response is smooth and peak-free from 60 to 13,000 cycles and is specially compensated for chest resonance. The output level is -57 db. The pickup pattern is omni-directional, becoming slightly directional at extremely high frequencies. Mike case is 1" in diameter x 4" long and is furnished with clip. A small rubber desk stand is available. Complete with neck cord and clip, belt clip for cable, desk stand and 18 feet of cable \$80.00. Write for bulletin 201.

Electro Voice is also issuing their brochure explaining Hi-Fi techniques. Called "Temples of Tone" the 16-page booklet will be sent to those requesting it and enclosing 10 cents to cover handling and postage. For those interested in Hi-Fi reproduction it might be the best 10 cents they ever invested. Order from Electro Voice, Buchanan, Michigan. Ask for Bulletin 216.

HEAD ALIGNMENT BULLETIN

Minnesota Mining and Manufacturing Co., St. Paul 6, Minnesota, is offering free to those requesting it their "Sound Talk," Bulletin 27 which takes up the problems of recording head alignment and head wear. The three page bulletin covers azimuth alignment, tape skewing, importance of head contact and the effects of head wear.

NEW TAPE ANNOUNCED

Technical Tape Corporation, Magnetic Products Division, West 177th Street and Harlem River, New York 53, N. Y., announces the newest tape to enter the field. It is called "Tuck Tape" and is a high quality, recording-plastic base tape which will be available in all standard sizes. The seven inch, 1200 foot reel will sell for \$5.50 and the 625 foot reel for \$3.50 through jobbers and dealers. The firm has been in the masking and pressure sensitive tape business for many years and is making its bow in the magnetic tape field with its Tuck Tape.

Dealers and industries may write to the manufacturer for samples and price list.

(Continued on next page)

for the "FULL TONE" RECORDING
your performance deserves

**TAPE IT WITH
EICOR**



Here's real sound. From thunderous lows to bell-like highs, all faithfully, economically, effortlessly recorded. Amateurs like Eicor's simplicity of operation, professionals praise its ruggedness of construction; all agree that Eicor's quality performance and low price, put it in a class by itself. A demonstration will show you too, why Eicor is your best buy in tape recorders.

MODEL 230—\$169.95 list

slightly higher west of the Rockies.

Plays both 7½ and 3¾ inches per second. Frequency range of 70 to 8,500 cycles at 7½ ips. Compensating switch equalizes the amplifier for both speeds. Fast rewind and fast forward: 15-1. Weighs only 28 pounds. High impedance crystal microphone. Dual track, plug-in recording head. Tape capacity: 2 hours.

Eicor recorders are in daily use by schools, churches, professionals, amateurs, and in fact every type of recorder user. Eicor's amazing versatility provides what you have been looking for in a tape recorder. Manufactured by one of the pioneers in tape recording, the Eicor is a product of years of patient laboratory research and field trial. Every Eicor recorder sold carries a TROUBLE FREE GUARANTEE, your assurance of the quality and satisfaction you must demand of a modern recording instrument. Your Eicor dealer will be glad to demonstrate the 230 for you. See him today. If you do not know the location of your nearest dealer, fill out the coupon below.

Model 400—\$119.50 list

slightly higher west of Rockies.

Same mechanism as Model 230. Tape speed: 3¾ ips. Weight: 24 pounds. This model is designed to give quality performance without costly extras.

Get the facts
Today



1501 W. Congress St.
Chicago 7, Ill.

EICOR, Inc., Dept. FT-3
1501 West Congress Street
Chicago 7, Illinois

Gentlemen:

Please send latest literature on Eicor 1954 models.

Name

Address

City State

HI-FI MAGNETRONIC HEAD



The Dynamu Magnetronics Division of the Maico Company, Maico Building, Minneapolis, Minn., has announced the production of a new type of Magnetronic head which breaks both the upper and lower frequency barriers for home and professional machines.

With the new head, which is based on a combination of electronics, magnetics and optics, it is claimed that the entire human hearing range of 20 to 15,000 cycles may be reproduced with standard recorders. The heads operate on magnetronic rather than purely magnetic principles and are available for installation on almost all types of recorders. The heads are available through tape recorder dealers complete with instructions and will cost about the same as the better magnetic reluctance phonograph pickups. Write the manufacturer for a free booklet, "Dynamu and Ynu."

NEW AMPEX REELS



A new 1200 foot reel using the standard NARTB hub to eliminate tape stretch, breakage and pitch changes as the tape approaches the end of the reel has been announced by Ampex Corporation, Redwood City, California. The new 8-inch all metal reel can be used on any machine which takes the NARTB hub, and will sell for \$2.50. Also available are the all metal 10½ and 14 inch reels.

FREE REEL TABS

ORRadio Industries, T-120 Marvyn Road, Opelika, Alabama, makers of Irish tape, are offering a free 5" reel tab for marking reels. Write to Nat Welch at the above address.

NEW 8MM. RECORDING-PROJECTOR

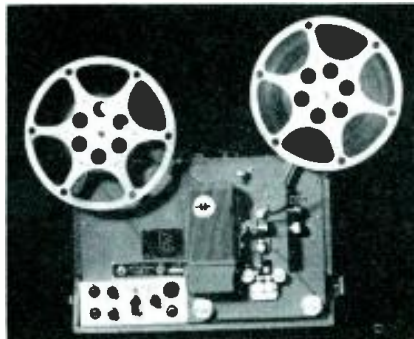

The Calvin Company, 1105 Truman Road, Kansas City 6, Mo., announces their new, improved 8 mm sound projector, the Movie Sound 8, Model T-54. The machine will feature two sound heads for finer quality recordings on 8 mm film. Other features include an advance design shutter giving 33 per cent more light on the screen and lifetime lubrication of all moving parts.

The projector has an improved roto magnetic stabilizer system to insure low flutter and minimum wow when recording or playing back sound tracks. Separate record-playback and erase heads are provided.

PORTABLE HI-FI SPEAKER



Jensen Manufacturing Company, 6601 South Laramie Avenue, Chicago 38, Ill., announces the "Duette" Model DU-202 portable two-way hi-fi loudspeaker system. The new Jensen can be used with tape recorders, portable record players, etc. The "Duette" is built into an attractive black leatherette covered case with a convenient carrying handle at the top. A snap-lock lid holds a 25-foot cable and also provides storage space for two 7" or three 5" boxes of tape.

The unit features a special 8" heavy duty "woofer" and a multicell horn compression driver "tweeter" with a built-in frequency dividing system. It has a full 20 watt power rating. The net price is \$89.50.

RCA RECORDER ACCESSORIES

As accessories to its Push Button Recorder RCA is offering a number of items, most of which can be used with any machine. A zip on cover for the recorder, to protect the finish is one item. Another is a plastic carry-all with a zipper cover and shoulder strap which will carry five reels of sound tape and is available in either the 5 or 7 inch reel size. A smaller item is the adhesive back reel tabs for labeling tapes. All are available from RCA dealers.

BINAURAL PLAYBACK PRE-AMPS

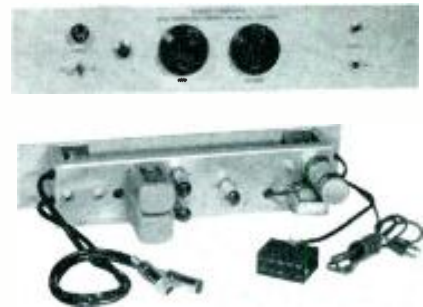

The Audio Division of the Eder Engineering Company, 1568 S. First Street, Milwaukee, Wisconsin, has announced the first of four units of a new series of binaural equipment. They are playback pre-amplifiers, two for tape and two for disc. All units feature balance and gain control and proper equalization in all units. The units are self-contained and all are identical in panel appearance. For further details and prices write to the company.

PENTRON PLAYBACK

A mechanism designed solely for the playing of magnetic tapes is being offered by the Pentron Corporation, 221 E. Cullerton Street, Chicago 16, Ill. A substantial reduction in cost has been achieved by the elimination of the recording part of the unit. It was specifically designed for classroom use to enable schools to add tape players to classrooms. The new player, Model PB-A2 weighs 22 lbs. Write Pentron for details and prices.

CRASHPROOF RECORDER

North American Aviation has designed an airborne tape recorder that is fire and crash proof. Designed to record everything that happens during a plane or guided missile flight it will run up to 10 hours. Service checks are not necessary until after 500 hours of operation. Approximately the size of a portable typewriter, the unit is sealed in a crash proof case. Total weight is about 18 pounds.



"I still think that if we're going to record animal voices, the best place would be the Zoo."

QUESTIONS & ANSWERS

Questions for this department may be sent on tape or by means of a postcard or letter. Please address your queries to, "Questions and Answers," Film and TAPE RECORDING, Severna Park, Maryland. The most interesting and widely applicable questions will be used in this department and all inquiries will receive a tape or letter reply.

Q—I have looked through the literature but do not seem to be able to find anything on the subject of full track vs. half-track. Assuming the same recorder, same speed, same tape, etc., how much difference is there between full and half-track recordings?—G. S., Montgomery, Ala.

A—Full track recordings will have almost double the frequency response and improve the gain over a half-track, other things being equal. For instance, if a half-track recorder will record 5,000 cycles a second at 7½ i.p.s. and the same machine could be switched to full track you would find the frequency response would increase to about 8,000 cycles and the volume of the recording would also be greater. Most professional machines record at full track, but at the rate improvements are being made today, it would not surprise us to find remarkable fidelity coming from the half-track.

Q—Why is it advisable to rewind tape before playing and why should it be stored in film cans if being kept 5 years or more.—H. Y., S. Portland, Maine.

A—Rewinding of stored tape before playing will remove any stresses or strains that may be present and also break any adhesions between layers. Film type cans are used to keep the tape at the proper degree of humidity so it will not dry out.

Q—Although I followed your procedures outlined in "Recording the Piano" in your February issue, I still do not receive what I consider a good piano tone.

I have used several microphones (both low and high impedance) and several medium-priced recorders. The principal difficulty is in the middle tones which tend to sound "tinny" and "fuzzy."

I would appreciate suggestions which might result in a better piano recording—other instruments sound good with the same setup.—A. P., San Francisco, Cal.

A—Several factors could cause the middle tones of your piano to sound tinny or fuzzy on your recordings.

If the room in which you record is particularly live—that is, if it has large, smooth surfaces for the floors and walls, then it might happen that the room has a natural resonant frequency which falls around the middle register of the piano and reinforces those tones more than normal echo. The fact that the piano is a percussion instrument would make the effect greater and hence more noticeable than with other instruments.

Should such condition occur, scattering a few rugs around the room and perhaps draping one or more opposite walls, should break up the reflecting surfaces sufficiently to eliminate the defect.

Sometimes the difficulty lies within the instrument. If the normal damping of the strings is decreased by wear, particularly around the notes of the middle register which are used most in normal playing, then again those tones would sound fuzzy and tinny. In some cases a loose sounding board, or if the frame upon which the strings are mounted happens to be loose, there occurs a sympathetic vibration of these members, which generally covers the middle register, and thus introduces the distortion noticed.

The usual remedies in these instances are: replacing worn damping felts and tightening loose frames and sounding boards. A quick fix can sometimes be obtained by slipping a small rug directly under the middle register portion of the piano. In this way floor reflections to that portion of the sounding board are cut to a minimum and may thus lessen the amount of sound produced at those frequencies by the piano to a point just below the distortion level.

There are times, however, when the wood of the piano either changes in quality or shape and thus changes the resonant qualities of the whole sounding board. Here you may find it necessary to open up the sounding board opening—if you have one—as much as possible. Playing softly would also help decrease distortion in such a case. And as an extreme, an oblong piece of felt might be glued inside the sounding board opposite the strings of the middle register.

One more thing: you mention that you used microphones of both high and low impedances. Now, unless you match the impedance of your recorder (high to high and low to low impedances) you will introduce distortion in your recording. Such distortion would be particularly evident with the sharp impact characteristics of piano tones, especially those of the middle register which have more volume than the others at normal distances from the microphone. So in this instance, correct matching might effect a remedy.

I am sure that I have not covered all the possible causes of distortion for piano tones in the middle register, but I hope that the above suggestions are helpful at least in permitting you to isolate the difficulty to the room, the piano, or the equipment and then in effecting a suitable remedy which will result in your obtaining better piano recordings. L. L. Ferkas

Q—I have a script which I want to tape, but some of the sound effects call for boat whistles and battle noises. How can I make them?—J. M., New York, N. Y.

A—Your best bet is to get the sounds you need from one of the sound effect record companies. The records are inexpensive and the variety of sounds available is very large.

RIDER'S "BEST SELLERS" for SOUND from A to Z



GUIDE TO AUDIO REPRODUCTION

by David Fidelman

Here's an a to z explanation of the reproduction of sound... from the fundamentals to all phases of audio reproduction systems. Design, construction and assembly of these systems and their components. Comprehensive methods for testing individual units. Explanation of circuitry of pre-amplifiers and amplifiers. Complete discussion of pick-up devices (phono cartridges, tuners and microphones), loudspeakers and enclosures. Charts, tables and graphs keep mathematics to a minimum. Engineers will value the book for design charts and testing methods. Practical circuits for home or custom construction enable building of systems tailor-made to individual needs.

ONLY \$3.50



HIGH FIDELITY SIMPLIFIED

by H. D. Weiler

LIFE magazine's June 15, 1953 issue reported enthusiastically how "High Fidelity Simplified"—the only book quoted—explains the complete Hi-Fi story. RADIO-Television News stated: "Those planning high fidelity music systems for their homes will save themselves time, money and trouble by reading this first, then making purchases. Typical Chapters: Sound; Acoustics, Electronics and Music; The Simple Loudspeaker; The High-Fidelity Loudspeaker; Loudspeaker Enclosures; The Basic Amplifier; The Amplifier—Part 2; The Record Player; The Tuner; Use of the Music System; Tape Recorders.

ONLY \$2.50



OBTAINING AND INTERPRETING TEST SCOPE TRACES

by John F. Rider

People interested in audio will welcome this book which shows over 500 actual photographs of test scope traces. Complete explanation of how to use scopes and what test scope traces mean. Valuable for audio systems and test equipment and also for TV receivers, and FM and AM receivers. Specific test equipment set-ups are shown with each application. There is no other book like it! Typical Chapters: What's in a Scope; Getting Familiar with the Scope; Auxiliary Test Equipment for the Scope; Using the Scope for Checking Test Equipment; Checking Audio Systems With the Scope; the Scope's use in Checking Components, and four other chapters.

ONLY \$2.40

Buy these books now from your Jobber, local bookstore or, if unavailable from these sources, write to:

JOHN F. RIDER

PUBLISHER, INC.

480 Canal Street, New York 13, N. Y.

MAGNETIC RECORDING

by S. J. BEGUN

Here is a thorough engineering treatment of what is known today of magnetic recording written by Mr. Begun, vice president and chief engineer of The Brush Development Company.

Chapters include:

- 1—History of Magnetic Recording
- 2—Acoustic Factors in Magnetic Recording
- 3—Fundamentals of Magnetism
- 4—Theory of Magnetic Recording
- 5—Components of a Magnetic Recording System
- 6—Magnetic Recording Equipment
- 7—Applications of Magnetic Recording
- 8—Instrumentation and Magnetic Recording Measurements
- 9—Magnetic Recording as a Challenge to the Phonograph

Complete with bibliography, glossary and index.

THIRD PRINTING

\$5.00 postpaid

Order today from this ad.

Magnetic Film & Tape Recording

SEVERNA PARK, MD.

TAPES TO THE EDITOR

When sending tapes to the editor please use the 3" reel and indicate the speed at which it was recorded and whether it is dual or single track. We will listen to your tape, make notes from it for use in this column and then reply on your tape. Please keep tapes reasonably brief.

If you do not own a recorder a letter will be acceptable. Address tapes or letters to: The Editor, Film and TAPE RECORDING, Severna Park, Md.

To the Editor:

This magazine seems destined to fill a long needed void for tape recorder fans so I extend to you all most hearty congratulations. I patiently awaited the receipt of this new magazine and I must say it has fulfilled my expectations—and more. As to suggestions, sure, I've got lots of them, probably every tape recorder fan has, but for the present I feel that after doing such a fine job on your initial issue we should grant you a chance to get into your stride before smothering you with too many ideas. My only lament at the moment is the fact that I must wait two months for every succeeding issue but in time that may also change.

My son in the Army got me started in this hobby which has expanded so fast that I now have two tape recorders, mixers, three record players, AM and FM radio, two hi-fi amplifiers, pre-amps and all the other equipment. Unfortunately, my knowledge of electronics and magnetic recording is nil so you see I positively drool for any kind of reading matter that will enable me to gain a bit more knowledge about this hobby. The pleasure I have gained from recorders is immeasurable. I ordered two recorders, one for myself and one for my son, and they have brought the family together.—*Harry B. Bicher, Hackensack, N. J.*

Mr. Bicher also mentioned on his tape that he had just completed a six channel mixer with a VU meter so we think his estimate of his knowledge of electronics is modest. But we do want suggestions. If they show signs of smothering us we'll just raise the snorkel and keep going.

To the Editor:

I'd like to start a Spike Jones' Fan Club. So far as I know there is none in existence. I'd prefer teen-age members as I am 17 years old myself, but I wouldn't exclude adults. Just anyone who is interested in Spike's extremely high fidelity recordings would be eligible. I have about 300 records, mostly Spike and novelties and am now switching to tape. Can tape be purchased in bulk, like bulk film that you load yourself? I use up tape like Spike Jones uses up cowbells.—*William Faria, 76 Division Street, New Bedford, Mass.*

We're passing the word along to you readers. Spike Jones fans can contact Mr. Faria by tape or letter. Tape may be purchased in bulk on hubs instead of reels at a saving.

To the Editor:

How come someone hasn't thought of a magazine like this before. This is the greatest thing I've ever seen. I enjoyed the mike mixer article and am looking forward to the one on the decibel. I'd like to see more

how-to-build articles, especially on accessories. Keep up the good work. This magazine is just what the amateur recording fan needs.—*Bob Crutchfield, Houston, Texas.*

Thanks for the kind words pardner and we'll try to keep deserving them. We'll see what else we can dig up in the how-to-build line.

To the Editor:

Page 34 of your first issue states that the post office has announced a decrease in mailing rates on tapes. This is just enough information to tantalize a reader. Why not clear it up completely in the next issue with complete rate information for your readers? What rate applies to new or blank tapes? What rate on radio transcriptions and other copyrighted material. What rate on personal messages or correspondence?—*H. P. Richmond, Virginia.*

OK, here it is, straight from the Post Office. "Tape recordings constitute matter of the third or fourth class depending upon the weight of the parcels. The nature of the matter recorded on tape recordings would have no bearing on their classification."

Third class matter goes up to 8 ounces, over that it is fourth class (parcel post). The reduction mentioned was made in mailings of tape or sound recordings to or from "schools, colleges, universities, or public libraries and religious educational, scientific, philanthropic, agricultural, labor, veterans' or fraternal organizations not organized for profit and none of the profit of which inures to the benefit of any private stockholder or individual. The rate is 4 cents for the first pound or fraction thereof and 1 cent for each additional pound. This special rate applies only to parcels of such materials addressed for local delivery, for delivery in the first, second or third zone or within the state in which mailed."

To the Editor:

I saw the TAPE RECORDING magazine in a drug store and bought it. Enclosed is \$2.00 for a subscription. It is a wonderful magazine.

I have a Revere tape recorder (3¾ i.p.s.) and a Masco disc cutter. I am a member of Alcoholics Anonymous and I take the tape recorder to different group meetings and have members give a short A.A. talk and then cut records of the talks and send them to groups in Ireland, Scotland, England, Canada and, of course, the U.S.A.

This occupies most of my spare time. For those who have a machine to run them off, I send full tapes of speeches. I can play the guitar, mandolin, uke, banjo and bones so I send them a little entertainment, and as my name is William Bailey the number most in demand is "Won't You Come

Home Bill Bailey."

I enjoy the magazine immensely and this hobby keeps me out of the booze joints. So if you know of any A.A. groups who would like a record, or a 3 3/4 tape, I would be glad to exchange full speeches with them. Could you tell me how to cut good records from tape as I cannot get my records to sound as good as the tape?—William E. Bailey.

Anyone wishing to write to Mr. Bailey may do so c/o TAPE RECORDING, Severna Park, Maryland, and we will forward the letters to him. We are planning to have some articles on cutting records from tapes and tapes from records.

To the Editor:

I was pleasantly surprised to find your magazine on the stand. I have been looking a long time for a magazine devoted solely to the home recording fan. I believe I read every word of it from cover to cover and enjoyed every bit of it.

There is one thing I would like to mention, however. Although I realize that tape is becoming the most popular medium for recording there is still a need for disc recording. For instance, when someone does not own a tape recorder and wishes a copy of a recording that is on tape. The material then must be re-recorded on a disc. Therefore, I hope the subject of disc recording will not be entirely overlooked in your magazine. — Jack Melbush, Amityville, N. Y.

We will be doing stories on the dubbing of music or sound effects from disc to tape and from tape to disc and have them lined up for future issues. The regular recording techniques, such as microphone placement, etc., are applicable to both tape and disc.

To the Editor:

I received a subscription to your magazine as a gift. Though not as technical as I would like it, it is a splendid magazine. I've been a tape enthusiast for four years. Before that time, I had been involved in disc recording.

I had expected a more complete mixer article than the one appearing in the last issue. I was especially hoping for a three-channel (2 mikes and a phono input) circuit. Electronic, that is. I doubt all your readers are tape novices.

Here for the record are some uses for recorders which I hope might interest or amuse your readers should you print them:

I record what I call Personality Archives. These consist of TV or FM air shots of famous people. I do this for several reasons, the main reason being that when we acquire a family, I want the children to know what the stars of yesteryear sounded like. In time they'll be collectors' items.

Most folks have a guest book for visitors. In our home we have a guest book in sound. Every visitor to our house tells his name and address and a few ad lib lines of his own. In years to come, this too may be of importance.—Joseph L. Quinn, South Paris, Maine.

Mr. Quinn's letter contained many other uses for a recorder for which we do not have space at present. George Thompson who did the mixer article is working up plans and circuits for an electronic mixer which will appear in a future issue.

dictate reports accurately-promptly!

make your car,
boat or plane
a "rolling
office"

with

ATR

INVERTER

for changing your storage battery current to A. C. Household ELECTRICITY

Anywhere . . .

in your own car!!

ATR INVERTERS . . . especially designed for operating standard 110 volt A. C. . . .

- TAPE RECORDERS
- WIRE RECORDERS
- DICTATING MACHINES
- ELECTRIC RAZORS

for

- EXECUTIVES
- SALESMEN
- PUBLIC OFFICIALS
- POLICEMEN
- FIREMEN
- OUTDOOR MEN
- REPORTERS
- FIELD INSPECTORS
- DOCTORS
- LAWYERS, ETC.

See your jobber or write factory

NEW MODELS ✓ NEW DESIGNS ✓ NEW LITERATURE
"A" Battery Eliminators, DC-AC Inverters, Auto Radio Vibrators

AMERICAN TELEVISION & RADIO Co.

Quality Products Since 1931

SAINT PAUL 1, MINNESOTA—U. S. A.

ATR

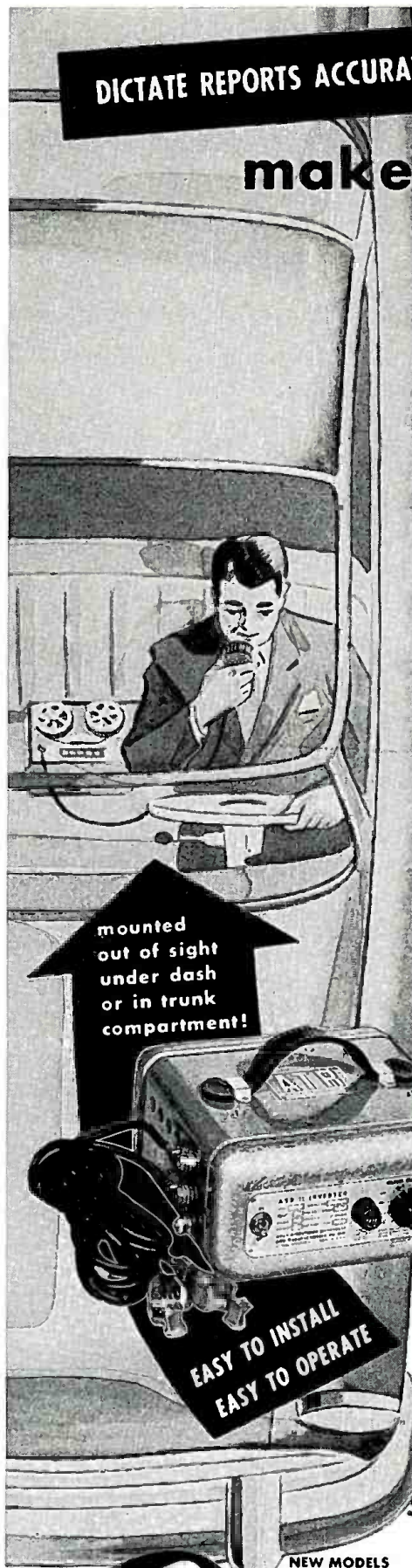

mounted
out of sight
under dash
or in trunk
compartment!

EASY TO INSTALL
EASY TO OPERATE

Recording Vocals With Piano

by L. L. Farkas

writer and producer formerly with the Columbia Broadcasting System

. proper microphone technique can make your recordings tops.

IN THE discussion of piano pick-ups (January-February issue) the emphasis was placed on making the microphone set-ups and recording the tones of different piano types. A few hints were given on how to record a singer with piano accompaniment, but actually very little was mentioned about the problems of voice pick-ups. Nevertheless, if good recording results are desired, such pick-ups also require special attention.

Let us assume, for the time being, that the piano set-up has been made and is satisfactory. The next step then is to locate the vocalist in relation to the microphone.

The best and quickest way to find the correct working distance is for the vocalist to take any comfortable singing position in front of the microphone and sing a selection which covers both his high and low ranges. The recorded characteristics of his voice can then be easily checked. If the volume at the two extremes seems approximately the same as that of the middle register, and the tones do not distort, the singer's position is probably correct. However, since very few voices have uniform volume over their full range, a compromise must generally be made: the singer should take the position from which the greater part of his tonal range is recorded without distortion and with fairly uniform volume. This can be called his average or normal position at the microphone. For the remainder of his range—that portion which is either too loud or too soft—the singer will have to make adjustments while performing. The way in which he does this is called microphone technique.

More specifically microphone technique may be defined as the best utilization of a singer's voice characteristics relative to the type of microphone and recorder used. Such complex explanation may make this technique sound like a highly difficult procedure, and perhaps this is the reason why so many professional vocalists on radio and television, and even on recordings, have disregarded it. Actually microphone technique, based upon common sense, is simple, easy to learn, and beneficial to any performance over a microphone.

In order to illustrate it let us take, as an analogy, water being forced through a hose into a bucket. When the water comes out of the hose with too much pressure or too suddenly, it spills out of the bucket. To prevent this the pressure must be reduced. Substituting a microphone and recorder for the bucket, sound for the water, and volume for pressure, we obtain the effect in which sound, transmitted with too much volume for the microphone and recorder to handle, will actually "spill over" or distort. The size of the hose, which will affect the water pressure, may be likened to the vocal cavity of the singer which determines the volume of the various notes produced while the size or shape of the bucket may be said to correspond to the different types of microphones in use. Now microphone technique does nothing more than prevent sound from spilling out of its particular bucket by reducing its pressure on the microphone and recorder.

The way to do this is obvious: the singer backs away so that his tones reach the microphone with reduced volume. This occurs because the volume of sound decreases by its square as the distance from its source increases. For example, the volume of sound reaching the microphone from a singer six feet away will be four times less than that received when he is only three feet from the microphone. Of course the vocalist could maintain a set position and reduce his own volume, but in singing, particularly with full voice, this is not a very easy thing to do, also especially without affecting the quality of the voice recorded. While there are a few exceptions, the majority of singers prefer to back away from the microphone on crescendos.

One additional point in our analogy: if the water pressure is too low, the water will probably not reach the bucket. Similarly tones too low in volume will not be picked up by the microphone or will come through poorly and often buried in the background noise. Microphone technique therefore also consists of boosting the tones too soft for normal recording. This means that the singer will have to move closer during pianissimo passages, when his voice volume is low.

An immediate protest will undoubtedly be raised that



CBS Radio Photo

Rosemary Clooney and Bing Crosby using the "on mike" singing technique. Note that Bing, with his soft tones and low register must work very close and across the face of the microphone. The knowledge of how to "work" a mike is a necessary part of any singer's stock in trade. A shift of a few inches toward or away from the microphone will take care of most variations in a singer's volume in the high or low registers.



CBS Radio Photo

"On mike" position used by Jo Stafford while singing over CBS radio. When the singer works close to the mike listen for sibilances, popping or breathy effects which will interfere with a good recording. Always run a test before taping.

all this curtailment of volume variations will kill the musical expression in any selection. Were all tones levelled, this would be true, but actually microphone technique deals only with the extremes of a singer's volume range, preventing peaks from being distorted when they are excessive, and soft passages from not being heard at all when their volume is too low. In reality the range of volume variations possible within the limits of volume handling capabilities of the microphone and recorder is sufficiently wide to cover almost all of the gamut of musical expressions.

Perhaps the most difficult thing about microphone technique is to learn not to overcontrol. When the vocalist goes back too far on a crescendo, the result is not the desired smooth swelling of tones without distortion, but a sharp fade accompanied by a change in the timbre of the voice. On the other hand, moving too close will cause the voice to boom, destroying its quality and intelligibility.

The exact distance to move in or out on very soft or loud tones depends upon both the voice and the microphone characteristics. For instance, the very low notes of a bass singer may resonate, at close range, with a portion of the microphone structure, thus causing the notes to boom through and distort. In this case the singer would have to back away, whereas with a different type of microphone, without the low frequency resonance, the same low notes might be too soft to pick up and the singer would have to move closer. A similar effect also can be caused by a difference in microphone sensitivity. For example, a soprano backing away on a crescendo of high frequency notes would

lose her effect when using a microphone of reduced sensitivity because the response of the microphone to her voice would drop off faster with the increased distance than with the first microphone. Of course these results would probably occur only when first using a new or unfamiliar microphone, for with usage the characteristics of the unit will become evident and the right technique used to compensate for them. However, as a rule of thumb, it may be said that with non-operatic types of songs, a variation of two to six inches from the singer's average position should be sufficient to handle most changes in volume, while in operatic singing variations up to a foot may be required.

Some vocalists have been instructed to turn their head sideways on crescendos. While this may work very well on a microphone with a wide pick-up angle, the effect becomes objectionable when using a microphone with a fairly narrow beam, such as the ribbon type. With the latter the voice volume will drop very rapidly as the singer turns away, but his tones will also lose their fullness and quality. It is therefore advisable to go straight back from the face of the microphone, thus precluding any possibility of moving away from the center of the pick-up beam.

At this time it should be pointed out that very few singers, with the possible exception of some basses, have excessive volume on their low notes. In many performances, when the passage with the low notes is reached, the listener will notice a decided drop in volume. This can easily be avoided by leaning forward slightly when singing the low tones. A movement of no more than two or three inches is



For the operatic type of voice a distant perspective is better. In this position distance changes of up to a foot may be necessary to equalize the volume. The equalization is necessary to prevent poor recording, or actual tone distortion.

generally sufficient to provide the necessary reinforcement in volume.

In all these movements toward or away from the microphone, the final check of the technique must naturally be the recording. For this reason a test run should always be made with the vocalist singing his selection and using the same microphone technique which will later be utilized during the actual performance. In this way such faults as "blasting"—caused by singing staccato passages too close to the microphone, booming on low notes, excessive changes in either the volume or quality of the voice: essentially all defects introduced by moving in too close or backing too far away, can be noted and remedied.

In some instances a singer will observe all the rules and still fail to obtain good recording results. This is frequently caused by unusual characteristics of his voice. One such type is the singer whose tones sound very harsh and breathy. Using normal technique the effect is very noticeable and objectionable; nevertheless it can be reduced and sometimes entirely eliminated simply by making the vocalist sing at an angle of approximately forty-five degrees from the face of the microphone. This deflects the full blast of his breath away from the diaphragm or sound pick-up element, thus reducing the breathy effect as well as decreasing the harshness of the tones. Slight fuzziness sometimes present in the voice, like sibilance, usually can also be remedied by this method. The angle used will undoubtedly vary with each type of voice, the amount of defect, and the kind of microphone utilized for the pick-up, but again the exact

angle can be determined very quickly by checking the results on a recording.

Another type of voice presenting a pick-up problem is that of the contralto or bass with low volume. A singer with that kind of a voice cannot come in too close because the bass response of the microphone will cause most of the tones to boom; and when he or she stands at the minimum working distance, the voice is too weak to be picked up correctly. The best way to remedy this condition is for the vocalist to take a position on the "dead" side of the microphone, that is, completely outside its pick-up beam, and then sing directly across the face of the microphone from a distance of about two inches. This will bring the source of sound very close in and thus produce increased volume without introducing the booming effect caused by the low frequency tones hitting the microphone directly.

A few words of caution should be added. Since various movements are required for microphone technique to handle extremes of volume, some vocalists have deduced that they must always move around a great deal while singing. Nor is this movement restricted to forward and back variations, for some artists have been known to weave sideways as much as a foot. Somehow they seem to think that this will put more feeling into their performance. Now this may very well be true of the visual portion of their act, but for sound recording, the effect of any such extreme and repeated variations is more like that of a person jumping in and out of a spotlight. This is opposite to the levelling tendency previously decried, but just as objectionable. The recording

will sound "spotty," with the sound volume increasing and decreasing abruptly during passages when the level should remain the same, while the quality and intelligibility of the voice will be greatly impaired.

Movement then, while singing over a microphone, must not be indiscriminate, but very much as in acting, must be motivated. And to repeat: the main reason for any motions while performing is to counteract excesses in volume caused either by very soft or very loud tones. In the singer's normal range very little movement is advisable. If expression is needed, it should be introduced by voice control, and not by abuse of microphone technique.

The above comments on motion while singing bring up a bad habit which many vocalists acquire quite innocently. You have undoubtedly seen the singer who, particularly while using a sound system in a hall or night club, will frequently raise his microphone up or lower it, will move it about, lean on it, and generally handle the unit roughly. Now disregarding the damage caused to the sensitive elements of the microphone—this will vary with the ruggedness of the unit, his singing is generally punctuated by loud crashes and other types of noise which are definitely detrimental to his performance. Sometimes, when the vocalist has walked over a thick rug, grasping the microphone will cause a spark of static electricity to jump from his fingers to the microphone stand. In such cases the audible crackle is reinforced by an electrical noise which can mar any recording. To prevent any such defects it is best not to handle or even touch the microphone during a performance; but if handling cannot be avoided, then it should be done slowly and carefully in order to keep any resultant noise down to a minimum.

Thus far the discussion has dealt with the position a singer must assume and the microphone technique he must use in order to display his normal voice to best advantage. But the question sometimes arises: what is the singer's normal voice for recording? Should he sing in a soft voice or with full volume? The answer of course depends entirely upon the singer's type of voice and the kind of performance he wishes to give; yet there is not always a choice. A person with a weak voice cannot sing in the manner of the operatic star who uses full voice. Neither can the same operatic star sound good nor use his voice to full effect in crooning. These two examples are extremes but they indicate how a person must be guided by the characteristics of his voice in choosing the kind of singing he will do. In a few instances a singer can work equally well with either a soft or full voice and cannot decide which type to select. He should then record a selection using first one method and the other. By comparing the results on the playback he should be able to judge their relative qualities and decide which type he prefers.

Now that the questions of voice pick-ups have been explored, there still remains the problem of picking up the voice and the piano together so that they are blended properly. Whether the singing is picked up over a separate microphone or on the same unit that picks up the piano is unimportant. It is true that with a separate microphone a greater control is obtained over the volume of both the voice and instrument and in this way the balancing of the two sound levels is slightly easier, but with a bit of care equally good results can be attained with each set-up.

In each case a recording must be made of the selection in which the voice and piano accompaniment appear. When the voice is picked up over a separate microphone, its volume can be adjusted by varying the setting of the mixer

control until the desired balance, in relation to the volume of the piano, is obtained. Roughly, the voice level is adjusted so that it is about twice as loud as the piano. When the singing is done over the piano microphone, then the singer must either set the volume of his own voice or, more practically, he must fix his position so that he obtains the desired volume. This is simple for all he needs to do is turn his head slightly, thus varying the amount of sound which will reach the microphone. However, should this action affect the quality of his voice, then he will either have to move straight back from the microphone or, if this makes playing the piano too awkward, the whole set-up will have to be changed to obtain the required volume balance of voice and piano.

But balancing sound levels is not enough to produce a good pick-up. Sound perspective, one of the basic and probably most ignored principles of microphone technique must also be considered.

Sound perspective is quite similar to visual perspective. As a person sees an object close by or far away, so a sound can appear to originate from a close or distant source. By listening intently to a selection whether on a recording or over the radio, and trying to visualize from the sound heard the positions of the persons and instruments, it is usually quite easy to differentiate the close from the distant sounds, very much as a person can tell in darkness whether a sound is close to him or distant.

Now when a vocalist sings fairly close to the microphone and also sounds through the loudspeaker as though he were standing close to you, he is said to be in an intimate or "on mike" position. If he sounds far away, then he is in a distant or "off mike" position. When considering a double pick-up, such as a voice and a piano, the important thing is that these two sources of sound should seem to originate from the same point; that is, they should have the same perspective. Then and only then can it be said that the voice and piano are truly balanced.

There are some people who will say that this is really going to extremes, that most listeners cannot tell nor care about perspective balance. Perhaps not everyone can detect such defect, just as in a painting the average person may not be able to point out an error in perspective; still most people will feel that something is wrong and this sense of disharmony, small as it might be, may be enough to mar a good artistic rendition.

On the other hand, extremes of perspective unbalance can be not only glaring but irritating. Pick-ups that produce a close-up of the singer while maintaining a distant perspective on the piano definitely show poor microphone technique. The vocalist is prominent, but the accompaniment, instead of acting as solid support for the singer, seems disassociated from him and is often lost, particularly during vocal fortissimo passages. When the opposite situation occurs—the piano is "on mike" and the singer is heard in a distant pick-up, there is again a severe distortion of the musical picture. The voice appears to come from somewhere behind the piano and very often will be drowned out completely by the heavy notes of the instrument. It seems reasonable, therefore, that, in order to obtain good recording results, perspective balance should be sought and maintained as much as possible.

Thus if the piano has been set up for a distant pick-up, the singer should take a distant position; if the piano has been set for a close pick-up, then the singer must perform "on mike." Of course, you can always start out with the



Hoagy Carmichael on a close pick-up for a combination of voice and piano. Here, only the front beam of the ribbon microphone is used to get better balance between voice and music. The correct position will vary from person to person.

singer, fixing his position either close or distant and then moving the piano to maintain the same perspective. It is really not important which one determines the pick-up position, provided that they are both the same.

Once the pick-up and the recording have been made, the most accurate way to check both volume and perspective balances is to play back the selection with the recorder loudspeaker adjusted for normal volume. Then take a position in the direct beam of the loudspeaker, about four to five feet away from the cone. Close your eyes or turn them away from the source of sound. By listening intently to the sound of the voice and instrument you should be able to tell very quickly whether the volume of one or the other is incorrect; and as indicated before, by using your imagination to visualize the singer and the piano, you can check whether their separate tones seem to originate from the same relative distance.

From all the factors mentioned, microphone technique may truly appear to be difficult to master, but progress can really be made quickly by keeping the following points in mind:

1. Find the correct working distance on the microphone for your particular type of voice.
2. Move the correct amount, forward or backward, to compensate for soft or loud passages; and check the results

on a recording to make sure that you do not over- or under-control.

3. Do not weave or make abrupt and unnecessary changes in your position while singing into the microphone.

4. Do not handle the microphone roughly during your performance, or at any time for that matter.

5. Choose the type of singing which will present your voice to best advantage.

6. Check the recording of your selection for the desired volume balance between voice and piano; then make the necessary corrections.

7. Make sure that the voice and piano perspectives are the same.

Remember that the above suggestions will not teach you how to sing; they only summarize the factors which you must observe when singing with piano accompaniment in order to keep your performance free from preventable defects. At first such defects may be numerous, but as you become more and more familiar with the inherent characteristics of your voice and its effects upon the particular microphone and recorder you are using, you will discover that your microphone technique will improve rapidly and the results obtained in your recordings will become more and more professional in nature. Here again practice is the way to perfection.

GIVE YOUR SLIDES A VOICE



by C. M. Waite

**Your color slides take on added interest
if you use a tape-recorded commentary.**

THE PROBLEM facing my cousin Chet was one that is common to amateur photographers. Week-end excursions and longer vacation trips had filled boxes and cabinets to overflowing with hundreds of color slides. They were excellent pictures and he enjoyed showing them to his friends. Occasionally he was asked to give an illustrated talk to neighborhood clubs, church groups and school classes. He had the projector, screen and all necessary paraphernalia to make up a score of lectures. Properly presented, they might even bring him some paid engagements, or at least expense money.

But although other camera fans had praise for his pictures it was obvious that their interest was not always shared by less expert viewers. In time the reason became plain. Good as the slides were, they needed to be vitalized by an effective story of their background and significance. The off-hand, rambling "talk" about them left a letdown feeling.

Chet decided that if he wanted to provide the fullest measure of entertainment for his audience it would be necessary to (1) organize his travel facts and experiences into a bright, coherent story and (2) present it smoothly, with no dragging or awkward lapses.

Sketchy notes, even a fully developed script, read aloud under the handicap of poor light proved to be only partially satisfactory. After much consideration he decided that there was only one way to achieve the results he wanted. That was with a synchronized tape-recorded commentary. So after some investigation into the tape-recorder market he bought a Revere Standard Model T-100 and was ready to go to work.

As I had a better knack than Chet at putting words together and reading them aloud I undertook to assist with preparing and recording the script. There were two essential facts we tried to keep constantly in mind. First, there must be no tiresome rambling or repetition. The description and informative matter on each individual picture must be written as concisely and entertainingly as possible. Second, the phraseology must be plain and uncomplicated so that the script would read smoothly when being taped.

This meant starting at the very beginning, with careful selection of the slides. Critical editing seems to be hard for amateurs. It tears their hearts to throw away shots they had labored so diligently to take, even though they came out light-struck, over- or under-exposed, cock-eyed or just plain uninteresting. If you are that way, why not ask some

now you can easily...

IMPROVE

AUDIO

PERFORMANCE

Use the famous
DUBBINGS' TEST RECORDS
which have enabled thousands of
Hi-Fi enthusiasts to calibrate phono
equipment without voltmeters.

**D-100—"THE MEASURE OF
YOUR PHONOGRAPH'S PERFORMANCE"**

**D-101—"THE MEASURE OF
YOUR PHONOGRAPH'S EQUALIZATION"**

with Dubbings' simplified methods

now the latest in DUBBINGS' Co.
devices — engineered to help you
adjust for peak performance...

THE FIRST COMPREHENSIVE

**TEST
TAPE**

ONLY D-110 AND D-111 TAPES

*"The Measure of Your Tape
Recorder's Performance"*

CAN TEST FOR:

- *Wow and Flutter*
- *Head Azimuth Alignment*
- *Frequency Response*
- *Signal to Noise Ratio*
- *Signal Level*
- *Tape Speed*



...recorded
exclusively on stretch-
proof, REEVES
SOUNDCRAFT
LIFETIME
professional tape!

**READ DETAILED DATA AND SPECIAL IN-
TRODUCTORY OFFER ON NEXT 3 PAGES**

TEST TAPE

the first and only comprehensive test tapes

Now, for the first time, you can calibrate, service and adjust your tape recorder completely for maximum performance by using *one* test tape—everything from setting proper volume level to aligning recording head.

These tapes are expected to serve you for many years to come, so they have been recorded on REEVES SOUNDCRAFT LIFETIME tape, the most durable ever developed... It is stretch-proof, moisture proof, exceedingly strong... and the highest quality professional tape available anywhere. Recorded with the finest available professional tape machines — produced by the FAIRCHILD Recording Company.



HAROLD D. WEILER, author of "High Fidelity Simplified," in his forthcoming book, "Tape Recorders and Tape Recording," states: "The DUBBINGS' Test Tapes are an absolute must for anyone interested in obtaining and maintaining peak performance from his tape recorder. Their use insures better tapes. They are more than just test tapes..."

TO ORDER, SIMPLY DETACH CONVENIENT STAMPED, ADDRESSED ENVELOPE AT RIGHT ▶

TEST RECORDS

the most widely accepted standard of performance

These highly acclaimed test records permit *every* owner of a Hi-Fi phonograph to make his system perform to the limit of its capability. No more questionable performance with expensive equipment. These records are also the best trouble shooting tools conceived. How much weight should the pickup arm have for proper tracking? What are the best tone control settings?... And the solution to almost any other problem for attaining peak performance... these records will do it for you.



TEST INDICATOR

proven accuracy at modest cost

For many years the only way to check an audio system's output was with a good vacuum tube voltmeter. Since voltmeters are expensive and complex, DUBBINGS has developed a very inexpensive, simple test level indicator for the audiophile. It is the only real substitute for a voltmeter, and can be used with ANY TEST TAPE OR TEST RECORDS.

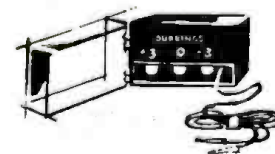

AUDIO SALES

select lines of quality components

The DUBBINGS Company, Inc. is an authorized agent for the leading audio manufacturers. Rather than list all these tested and proven components, just ask for our catalog, which describes the best quality-for-your-money equipment—on the order form at the right...

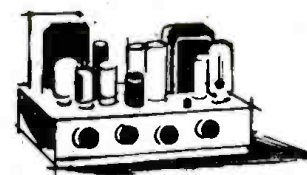

AUDIO SERVICES

Our other services include disc recording, tape duplication, off-the-air monitoring, master recording and many more. You can receive a bulletin describing these services by checking order form at the right...

The DUBBINGS Co., Inc., Dept. 44RT, 41-10 45th Street, Long Island City 4, New York

TEST TAPES

"THE MEASURE OF YOUR TAPE RECORDER'S PERFORMANCE"

- D-110 — 5" reel, 7½ ips
- D-111 — 7" reel, 15 ips

Recorded on REEVES SOUNDCRAFT LIFETIME magnetic tape made of DuPont "Mylar" Polyester film.

The only tape for indicating:

- Wow and Flutter
 - Head Azimuth Alignment
- Frequency Response
- Signal to Noise Ratio
 - Signal Level
- Tape Speed

for technical data see following page

TEST INDICATOR

D-500 TEST LEVEL INDICATOR

For use with any test tapes and test records...

The only accurate, yet inexpensive substitute for a good voltmeter. Consists of three bulbs calibrated to light up at 3 db intervals when connected across speaker leads.

TEST RECORDS

"THE MEASURE OF YOUR PHONOGRAPH'S PERFORMANCE"

D-100—12" vinyl disc, 33½ rpm

The only record for measuring:

- Frequency Response
- Rumble and Hum
- Wow and Flutter
- Tracking

"THE MEASURE OF YOUR PHONOGRAPH'S EQUALIZATION"

D-101—12" vinyl disc, 33½ rpm

The only record with these response curves:

- Columbia LP
- AES
- NARTB
- RCA's "New Orthophonic"

IN ADDITION... **AUDIO EQUIPMENT**
OF TESTED QUALITY IS FULLY STOCKED

at the **DUBBINGS** co., inc.

FOR YOUR CONVENIENCE . . .
AN ADDRESSED, POSTAGE FREE
ORDER ENVELOPE IS AT RIGHT

Simply detach along perforated lines, fill out and mail today

To Calibrate for
Peak Hi-Fidelity.
Performance use



exclusively engineered by
the **DUBBINGS** co., inc.

ORDER NOW WITH THIS CONVENIENT
POST-FREE, ADDRESSED ENVELOPE

FOLD

*FIRST FOLD HERE

Enclosed find CHECK MONEY ORDER

Quantity	Amount
<input type="checkbox"/> D-110 TEST TAPE 5" reel 7½ ips INTRODUCTORY OFFER @ \$10.95 (For Orders Received After May 15, 1954, cost is \$12.50)	\$.....
<input type="checkbox"/> D-111 TEST TAPE 7" reel 15 ips INTRODUCTORY OFFER @ \$15.95 (For Orders Received After May 15, 1954, cost is \$17.50)	\$.....
<input type="checkbox"/> D-500 TEST INDICATOR @ \$3.95 For use with any test tapes or records	\$.....
<input type="checkbox"/> D-100 TEST RECORD @ \$3.50 "The Measure of Your Phonograph's Performance"	\$.....
<input type="checkbox"/> D-101 TEST RECORD @ \$4.95 "The Measure of Your Phonograph's Equalization"	\$.....

Simple, complete instructions
enclosed with all the above.

FOLD

*SECOND FOLD HERE

<input type="checkbox"/> Fresh 7" Reel of REEVES SOUNDCRAFT LIFETIME Tape (\$9.75 list) @ \$6.50	\$.....
<input type="checkbox"/> Fresh 10½" Reel of REEVES SOUNDCRAFT LIFETIME Tape (\$19.80 list) @ \$13.20	\$.....

Postage & Handling \$.50

(*Enclose Remittance Between First and Second Folds) **TOTAL** \$.....

New 1954 Audio Catalog Recording Service Bulletin

UNCONDITIONAL MONEY BACK GUARANTEE!

NAME _____

ADDRESS _____

CITY _____ ZONE _____ STATE _____

I am a: PROFESSIONAL IN ELECTRONICS AUDIOPHILE

Please Print

**LISTEN...
TO
WHAT
AUDIO EXPERTS
ARE
SAYING...**

*comprehensive
technical specifications
on*

DUBBINGS':

**AUDIO
TESTS**

SEE PRECEDING PAGE FOR VITAL FACTS



BUSINESS REPLY ENVELOPE
First Class Permit No. 1851, Sec. 34.9, P.L.&R., Long Island City, N. Y.

The DUBBINGS Co., Inc.

41-10 45th STREET

LONG ISLAND CITY 4, N. Y.

DEPT. 44RT



SEE PRECEDING PAGE FOR VITAL FACTS

GEORGE MAERKLE, Chief Engineer, Fisher Radio Corporation.
"The DUBBINGS' D-110 and D-111 Test Tapes are the first to fill the long standing need for accurate and easily used means of evaluating and improving performance of magnetic recording equipment..."

ROBERT J. MARSHALL, Chief Engineer, Fairchild Recording Equipment.
"DUBBINGS' new Test Tapes are welcome companions to this company's series of fine test records. They demonstrate the same high calibre and are the only practical means for truly measuring the high fidelity tape recorder's performance. Getting all the important tests on a single reel is a tribute to advanced engineering know-how."

HAROLD D. WEILER, author of "High Fidelity Simplified," in his forthcoming book, "Tape Recorders and Tape Recording," states:
"The DUBBINGS' Test Tapes are an absolute must for anyone interested in obtaining and maintaining peak performance from his tape recorder. Their use insures better tapes. They are more than just test tape..."

D-110 TEST TAPE—"The Measure of Your Tape Recorder's Performance" 5" reel 7½ ips, REEVES SOUNDCRAFT LIFETIME Tape

WOW AND FLUTTER—3,000 cps tone • HEAD AZIMUTH ALIGNMENT—5,000 cps tone • FREQUENCY RESPONSE—30 to 7,500 cps in 13 steps 30, 50, 100, 200, 400, 700, 1 kc, 2, 3, 4, 5, 6, 7.5 kc. Recorded with standard NAB characteristic for 7½ inches per second. • SIGNAL TO NOISE RATIO—400 cps tone, 15 to 50 db in 5 db steps with announcements • MAXIMUM SIGNAL LEVEL—zero level, 400 cps, 3% total harmonic distortion • TAPE SPEED—timing beeps at 0, 5 and 10 minutes. Detailed instruction book enclosed.

D-111 TEST TAPE—"The Measure of Your Tape Recorder's Performance" 7" reel, 15 ips, REEVES SOUNDCRAFT LIFETIME Tape

WOW AND FLUTTER—3,000 cps tone • HEAD AZIMUTH ALIGNMENT—10,000 cps tone • FREQUENCY RESPONSE—30 to 15,000 cps in 14 steps 30, 50, 100, 200, 400, 700, 1 kc, 2, 4, 6, 8, 10, 12, 15 kc. Recorded with standard NAB characteristic for 15 inches per second. • SIGNAL TO NOISE RATIO—400 cps tone, 15 to 50 db in 5 db steps with announcements • MAXIMUM SIGNAL LEVEL—zero level, 400 cps, 3% total harmonic distortion. • TAPE SPEED—timing beeps at 0, 5 and 10 minutes. Detailed instruction book enclosed.

D-500 TEST LEVEL INDICATOR

RANGE—Calibrated for 3 db increments in level; 1 db increments can be judged easily • SENSITIVITY—Indicates at listening volume level when connected across 3 to 16 ohm loudspeaker terminals • FREQUENCY RESPONSE—Non-frequency discriminating, equally accurate at any frequency. Precision made, durable construction. Leads and alligator clips supplied. Detailed, easy to use instruction book enclosed.

D-100 TEST RECORD—"The Measure of Your Phonograph's Performance" 12" pure vinylite disc, 33½ rpm microgroove.

FREQUENCY BANDS—30, 50, 100, 250, 400, 700, 1 kc, 2, 4, 6, 8, 10, 12 kc., 4½ db/oct. attenuation below 500 cps. Constant velocity above 1 kc at 6 cm/sec level • ACCURACY—Within 1 db • WOW AND FLUTTER—3,000 cps tone • TRACKING TEST—5 bands of 400 cps tone at increasing levels: 2.5, 4, 6, 8½, 11 cm/sec. • UNMODULATED GROOVE—to check rumble, noise and hum. Both sides of record identical. Detailed, easy to use instructions on record cover.

D-101 TEST RECORD—"The Measure of Your Phonograph's Equalization" 12" pure vinylite disc, 33½ rpm microgroove.

FREQUENCY BANDS—30, 50, 100, 250, 400, 700, 1 kc, 2, 4, 6, 8, 10, 12 kc for each of the following recording curves, Columbia LP, NARTB, AES, and the RCA "New Orthophonic." An additional 1 kc reference band before each frequency run • ACCURACY—within 1 db. Detailed, easy to use instructions on record cover.

forthright friends to do the job? People don't enjoy seeing a poor picture, not even when a strained apology is made for it. "My exposure meter had a bug and on top of that a dog ran in front of the camera, and Aunt Sue who is behind the rock was blowing out cigarette smoke so it made Bald Hill look like a volcano." No. If you have to make excuses for a slide, better not show it except to friends intimate and understanding enough to share your feelings.

Having selected the best slides we tried to arrange them so that each sequence of views tied in naturally with those next to it. In some cases this was a chronological arrangement, in other cases geographic. Knowing that your script is to be recorded and will always sound the same inspires you to pay more attention to this detail. About the tenth time around you can get very tired of hearing your own voice saying, "This is the speed boat on old Mud Lake—remember, I told you about it when we were looking at the pictures of Mud Lake Dam?" Better put all the mud in one place and make a single puddle of it.

After selection and sequence there came the question of length. We decided as a starter to run two half-hour scripts. This would provide flexibility in showing to groups of varied interests. Each half-hour recording would be a complete, finished show but the two could also be presented as an entity.

Next were interlocking problems—how many slides to use and how long to talk on each. For our own particular purposes we decided that a half-minute average for each slide was long enough. Some were eventually allotted forty seconds, others only twenty, but most of them were close to the half-minute average. This meant sixty pictures for the half-hour show, 120 for the hour, and they were arranged accordingly.

For some people thirty seconds may seem a pretty short space of time to comment on a slide. In some cases it is. But it is also a positive fact that the average person giving an unplanned talk is prone to wander, repeat himself and go into too much tiresome detail. If you write your speech, then read it aloud, you will see many passages that can be eliminated and others that can be condensed.

This is not to suggest an arbitrary time limit of thirty seconds to a slide. The time element depends on many factors. But never forget that the most important factor is the audience itself. You are trying to capture their attention and hold it. It is—or should be—the picture that tells most of the story. The narrator merely illumines it with information or description.

For example, one of our longer sequences comprised fourteen views taken along the famous auto road up Mt. Evans in Colorado. The series shows the trees near timberline, the snowfields a little higher up. Here is the comment on them:

"The trees in this region of howling gales and polar temperatures manage to survive only by adapting themselves to a hostile environment. It is a grim and difficult

Top: About the narrowest four miles of highway in the United States. It is in the Capitol Reef National Monument. A summer shower can turn it into a river one to ten feet deep in a few minutes. Center: The trees near the timberline region manage to survive only by adapting themselves to the hostile environment. It is a grim and difficult war, never entirely won. Lower: After timberline a region of unbroken rock and then snowline. These are partial examples of the interesting facts that keep the audience listening to your recording and looking at your slides—with great pleasure.

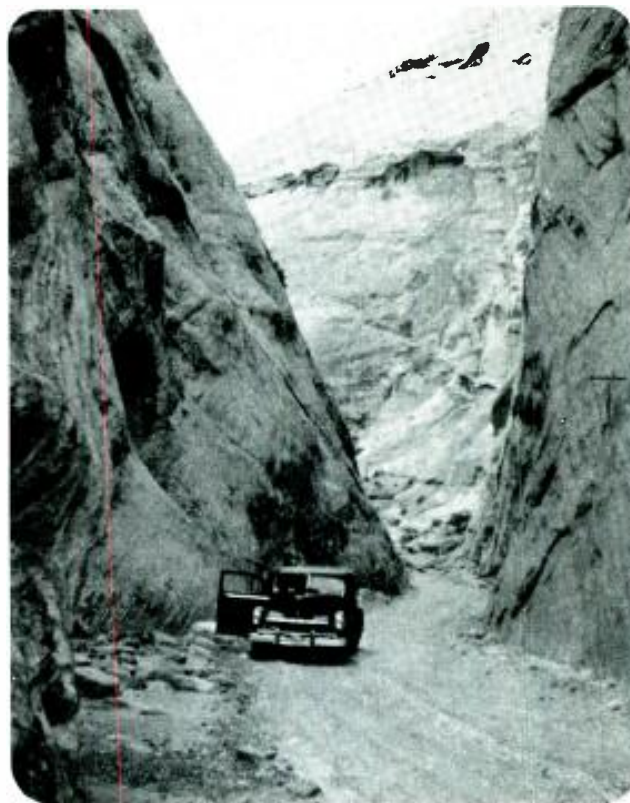



The slide collection should be viewed with a critical eye. All slides which are not excellent should be ruthlessly eliminated if you are interested in putting on the best possible show.

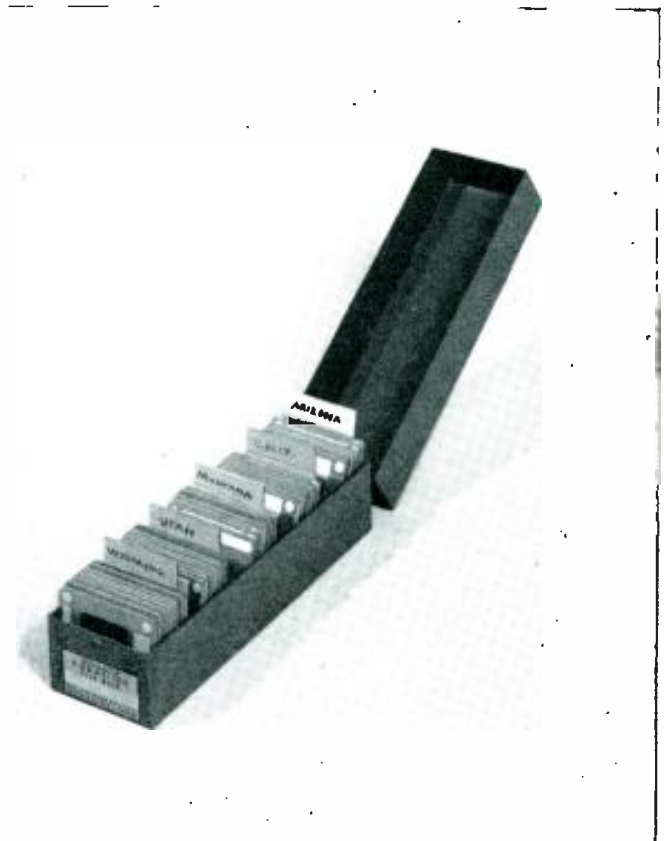

After the slides have been selected they should be grouped together and filed in a slide box. All should be thumb-spotted and in order, to match the sequence of comments that you have recorded on tape.

war, never entirely won. The wounds of battle show in broken, twisted limbs and stunted growth. The trees will hang on tenaciously for a few hundred feet more, continually becoming more dwarfed and deformed. But inevitably they must surrender and leave the fight for life to the shrubs and lichens and mosses.

"After timberline, a region of unbroken rock, then snow-line. Here is the place where you wish you had brought along an overcoat. When you look at the depth of the snow, and then stop to think that this is early in summer, you realize what a brief time is given the tourist to take advantage of this unusual trip. It doesn't look like the fire-cracker season of July Fourth, but this picture was taken during that week. The road had then been open only five days."

Some of this is merely fill-in material. With seven minutes to talk about Mt. Evans, a somewhat leisurely pace was indicated. On the other hand there were only four slides of Capitol Reefs National Monument, so a greater amount of information had to be packed into each thirty-second period.

(A road winding through a deep canyon.) "Our next objective is Capitol Reef National Monument and to reach it requires an additional forty-five minute drive from Hanksville. Take a look at just about the narrowest four miles of highway in the United States. A summer shower can turn this road into a river from one to ten feet deep in a few minutes. Signs are posted warning drivers not to enter the canyon if a shower seems imminent. There were a few clouds in the sky but we took a chance and made it

safely. The cliffs crowding the edge of the road reach heights up to twelve hundred feet."

Of course, the commentary would get pretty dull without an occasional spicing with humor, anecdotes or lively stories which, however, should be pertinent to the subject. For example, while looking at the passenger motorboat crossing Crater Lake our audience is given some of the customary tourist spiel:

"The homeward-bound boat carried more passengers and we had fun exchanging notes. We learned that monsters of all kinds once lurked about this place—at least according to Indian legends. Among them were giant crawfish that could reach clear from the lake to the top of the cliffs and drag down any luckless mortal. These fearsome gods once had a war with equally terrible gods from distant lands. A chief deity was killed and his head thrown into the lake, where it still remains in the form of Wizard Island."

When completed, our script was carefully typed double-space. Three descriptive paragraphs, for three slides, were typed on each page. No sentences were carried from one page to the next. These steps helped to insure easy reading, with no sentences running together or left dangling while a page was being turned. The tape recorder is ruthless in showing up the tiniest stumble or hesitation.

In the course of making up the story I had read it several times. At its completion I did so again for a final check. There were still two or three involved sentences that needed to be changed for smoother reading. Some tricky words were deleted or substitutes found. Here and there were a

succession of sibilants that needed attention. Overlong phrases were chopped down.

Before "shooting," another matter occurred to us. There must be some unobtrusive way of telling the projectionist when to switch slides. It wasn't practical to expect him to follow the recorded talk on a duplicate script. Experimenting with various objects we finally found a metal ashtray that gave out a soft, musical ping when tapped with a pencil. It was a sound that could be heard easily by the operator of the projector, but went unnoticed by the audience after two or three tinkles.

At last we were ready for some trial runs on the tape recorder. The quietest place in the house was the basement rumpus room where the only noise hazards would be the hardly discernible ones from above—the possible sound of doorbell or telephone bell, or unpredictable Polly, the parrot. Polly proved to be quite cooperative. She only let out one squawk penetrative enough to require wiping off the tape.

I sat at a table with the mike about sixteen inches in front of me, trying to remember not to crackle the paper as I read. Across from me cousin Chet engineered the recorder. At the end of each descriptive paragraph I raised my finger and he gave the ashtray a single light tap. We experimented and played back a few times until the various effects seemed as perfect as we could make them.

Now we set sail. Everything went smoothly for three or four pages. Then, "unaccustomed as I am to public speaking," I bobbed a couple of words. The "Grand Canyon" became something like the "Canned Grunion." Had the talk been "live" that would have wrecked me. Spoken into the recorder it was no more than a laughing matter. Chet flipped the switches, wiped the tape clean of the offending paragraph while I straightened out my diction. Then we made a fresh start.

To a novice this feature of the tape recorder is easily

its most comforting. Mistakes are so readily erased and corrected. You can go back a dozen times if necessary to get just the result you want. I went back many more times than a dozen! Mine was mostly throat trouble. It got scratchy with the strain of steady talking. But no matter. Did I cough, wheeze, croak or rasp? Chet patiently wiped the tape clean of the offending paragraph while I sipped water or chewed a cough lozenge. Then we repeated, and went on with the tale.

Oh — I forgot the music. Before the script was read, Chet put a few strains from the electric organ on the tape. The same thing was done at the end. The final slide was a crimson sunset, with fade-out music. Old stuff but still effective.

The whole scripting-recording project took quite a bit of time but it was lots of fun. I had never even seen any of the places I wrote about, but Chet had brought home plenty of literature as well as his store of personal experiences so there was more than enough material to work with.

As most of Chet's shows are a solo performance he has found it convenient to set the recorder and projector handily on the same table. There are times, however, when the recorder is placed near the screen, for which purpose an extension cord is needed.

Was it worth the trouble? Definitely! The reaction of the audience now borders on enthusiasm instead of polite attention. So try a tape recorder if your slides are gathering dust. Then your friends won't have other engagements when you say, "Come over to the house and I'll show you my vacation pictures." You will soon understand why they used to shy away after you have recorded one of your impromptu, long-winded repetitious "slide talks" and then listened to it played back. But work up a smooth interesting commentary that will give your slides a voice and they will keep free of dust at least until you return with more from your next vacation.

If you operate both the projector and the recorder they may both be set up together on the table as shown. A pleasant audible signal may be used on the tape to indicate change of slides. The recorder may also be placed near the screen, if desired. The latter arrangement is the more familiar because audiences are accustomed to the sound coming from the screen, as is done in the movies. The proper volume should be ascertained before the show begins.

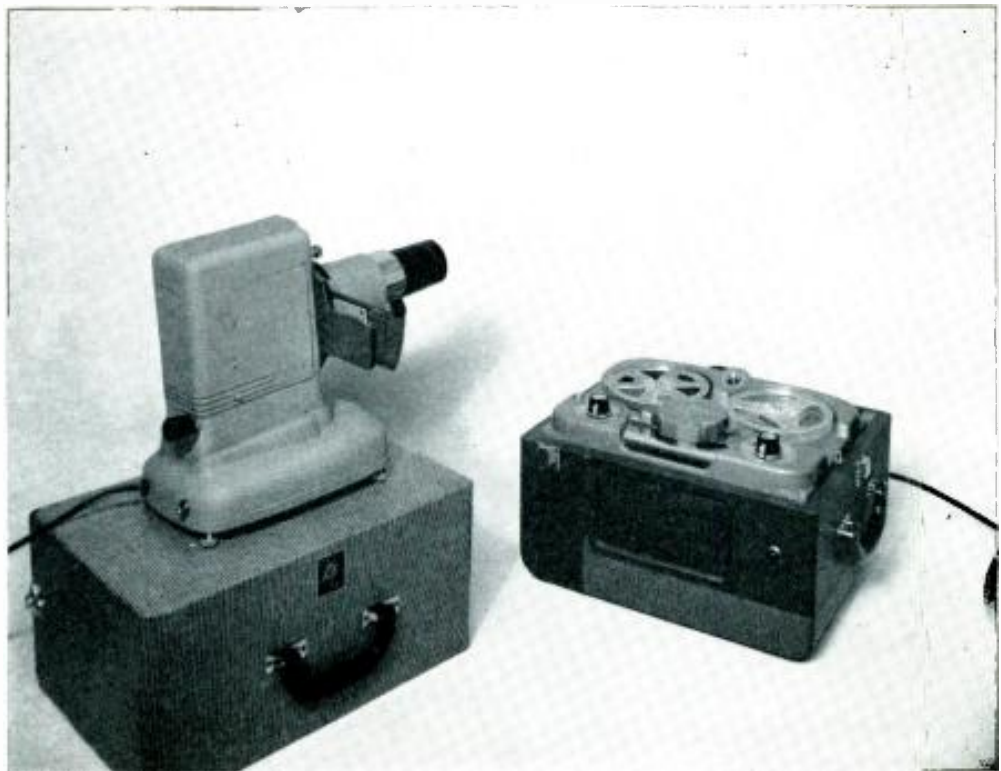



Don't Miss That Program

by Lou Burdick

. . . hitch your recorder to a clock radio and let it record programs you otherwise might miss.

A QUEEN is crowned, a president inaugurated, the United Nations hears an historic atomic age proposal, congress listens to a "State of the Union" message—and the world listens as the words pass into history.

Or didn't you hear them?

Unfortunately daily commitments usually make it difficult for you to remain at home where access to a radio receiver permits your enjoyment of these events to their fullest. When you stop to think of it, you have missed countless opportunities to hear such events because you just couldn't be in two places at the same time.

But wait, all is not lost—you *can* be in two places at once, figuratively speaking. You can hear a favorite program whether you are near a radio at the time or not. Not only

can you hear the event but you can also have a permanent record of it.

How? By attaching your tape recorder to a clock radio that will record the show you want to hear at any time, day or night. Momentous occasions can become a part of your treasured tape library too, when you record them.

While any clock radio may be attached to a recorder we have found the new "Quintet" by Webcor is not only a clock radio in itself but also features a jack into which the recorder may be plugged. Thus it will automatically turn itself and the recorder on at a preset time and record a program for you without your personal attention.

The sole remaining problem is turning the recorder off and the Webcor is equipped with stops to do that at 15,



The rear of the Quintet clock radio showing the special receptacle into which the recorder input cord is plugged. The recorder line cord is also plugged into the appliance socket on the clock radio.

30 or 60 minutes. Like bread and butter, the Quintet and the Webcor make a team.

All of the present day clock radios are built to turn something on but not off. The designers doubtless had in mind the radio waking you up to music in the morning and turning on the coffee pot at the same time. Once you were up, you shut the appliance off yourself.

Even with the Webcor recorder which does have the automatic shut-off feature, the radio will continue to play until you turn it off.

As recorders differ in construction, you can devise some means of shutting it off after the program has been recorded. In fact, an ordinary alarm clock can be rigged to operate a switch and cut off both the radio and recorder.

But even if you do not have a shutoff device there is no harm in letting the radio and recorder run until you can attend to them.

But let's take an example and see how it works.

You want to record an important event but, as usual, you won't be home at that given time. However, you're not dismayed because you have a clock-radio, that will connect to your tape recorder. The radio provides a sound output receptacle into which your recorder input cord plugs. The AC cord of the recorder also plugs into the clock-radio. A Webcor clock-radio and recorder are shown connected to illustrate the procedure. The "automatic on" or alarm hand, is set at 3 P.M. (the time of your program). The recorder is ready to operate because you have made the necessary connections and have made a test for correct volume level setting with the radio tuned to the appropriate radio station. You leave the house now at 8 A.M. with full assurance that your clock-radio will automatically turn on your radio receiver and recorder at the precise moment of the event and your recorder will record with full clarity and provide a recording that will become a valuable addition to your tape library.

The picture above shows the back panel of the Webcor clock-radio and its exclusive tape recorder output receptacle. This receptacle connects to the voice coils of the radio speaker and allows the radio program to be fed into the input of the tape recorder when the correct cord is used between radio and tape recorder. The AC plug of the recorder will, quite normally, plug into the AC receptacle of the radio.

While the Webcor Quintet very conveniently provides a recording output, the average clock-radio can be permanently adapted for this type operation. If permanent changes in the circuit are not desired, then temporary methods can be adopted. The microphone can be placed in front of the



If you do not care to install a permanent plug, as shown on the next page, you may set the microphone in front of the speaker. In either case, run a test for recording level before leaving the house.

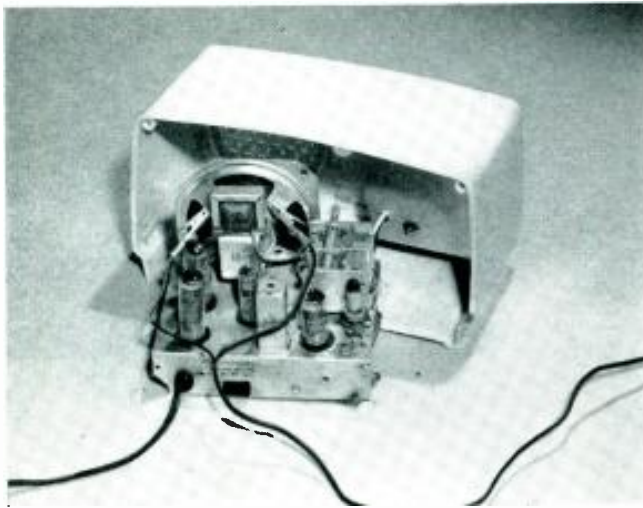

Above: a cord with alligator clips can be used to pick up the feed for the recorder. Clip to the speaker leads where they go to the voice coil. Do not let clips touch any part of the metal chassis. Upper right: to install a permanent jack, remove the back of the set and solder leads to the voice coil connection. Do not overheat the leads or you may damage the coil. Lower right: wedge points to the 8134 cinch receptacle mounted in the back of a clock radio.

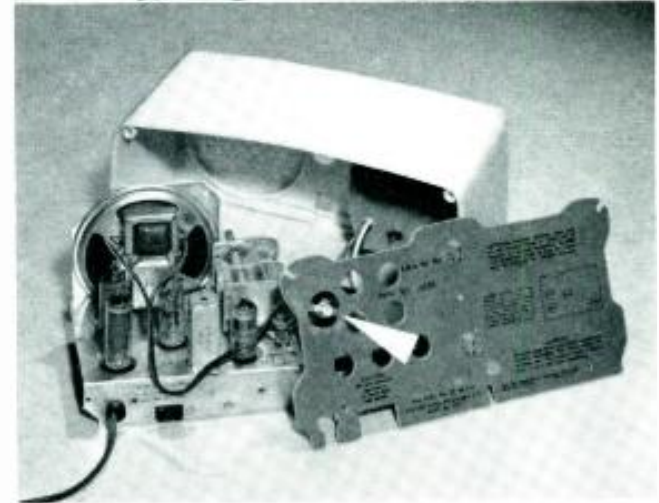
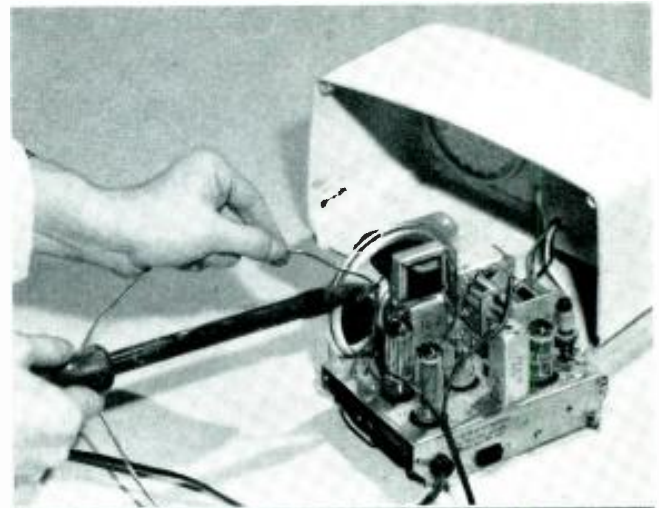

speaker to pick up the sound, as illustrated below, or temporary connections to the speaker coils using leads equipped with alligator clips can be made, as shown above.

These latter two methods both show disadvantages either in the quality of the recording itself or the inconvenience involved in the attachment and removal of the radio back panel and the cord leads.

Actually it is quite simple to permanently adapt a clock-radio for proper recording procedure. Tool and material requirements are basic and circuit connections are easily made. Should you desire to make such an adaptation, assemble the tools and material indicated, and follow the simple procedure outlined below.

<i>Tools</i>	<i>Materials</i>
Screwdriver	1/4" Wood Screws
Soldering Iron	Solder
Long nose pliers	1 foot of rubberized AC cord.
Brace and Bit	1 cinch—receptacle, No. 8134.
Wire skimmers or knife.	

Pull the AC plug of the clock-radio from the wall socket. Remove the back panel of the radio exposing the chassis and speaker. If the speaker coil terminals cannot be reached conveniently you may have to remove the chassis from the cabinet. When you have easy access to the speaker connect the cord leads—one to each voice coil terminal. Skin the wire ends of the 1 foot AC cord and wrap the leads around the terminals using the pliers to facilitate the operation. If the speaker has "flat" terminals, the leads can be soldered to the wires on the voice coil terminals. (Above right) shows the procedure. When soldering use the iron sparingly as the voice coil of the speaker can be damaged by prolonged heating. After soldering the leads to the speaker, you are ready to work on the other end of the cord. Route the cord so that it does not touch the receiving tubes of the radio and bring it out through the back opening of the cabinet. At this time you must be concerned with the radio's back panel. Drill a hole large enough to insert the terminals of the cinch receptacle. Use the 1/4" screws (or small bolts

and nuts) to secure the receptacle to the panel as shown above. The location of the hole in the panel will depend on the routing of the cord for the end of the cord must connect to the receptacle. The cord can be cut to a convenient length just so long as it reaches the receptacle when the panel is replaced on the cabinet.

The skinned leads of the cord can now be connected to the terminals of the receptacle as illustrated, however, before soldering the connections try making a test recording. To do this you must have the correct plug (a cinch No. M-93) attached to the end of the recorder input cord. If a loud hum is present in the recording, reverse the leads that connect to the receptacle on the back panel. After it has been ascertained that the correct connections have been made, solder the leads of the cord to the receptacle. After you have replaced the back panel, (and radio chassis, if you have removed it) on (and in) the cabinet, your work is finished and you now are equipped to record in the manner described earlier in this article.

Use your clock radio to record important events—automatically. Let it record for you while you are at work, at play or out visiting. Don't miss those programs you want to hear.

The by-product of using the clock radio technique is as important as the product! After you have listened to your recording of an important event, add it to your tape library. Start making a "Documentary Album" of famous moments in history. In years to come this album may become your most prized set of recordings.

NEW PRODUCT REPORT



SOUND CRAFT LIFETIME TAPE

. . . a mylar-base tape
that can take punishment

OUR usual course in preparing these reports is to use the material or machine in practical fashion, making things happen to it that would occur in both normal and abnormal conditions.

The "Lifetime" tape specifications claim that the new tape has a break strength two-and-a-half times greater than cellulose acetate tape, that its break elongation is four times greater, its impact strength two times as great, its tear strength five times as great, and its flex life at room temperature 500 times as great.

We wanted to find out what this meant on the tape recorder. We tried all the tricks we knew, flipping from full forward to full rewind, leaving loops in the tape and snapping them out. We put the tape under all the stress we

could on a recorder and failed to break it.

On a machine that rewinds a full 1,200-foot reel in about 40 seconds we deliberately flipped the tape over the edge of the reel so that it fell between the reel and the recorder while it was traveling at full speed. It wound around the shaft. We removed the reel and found the worst tape foul-up we have ever seen. We pulled the ball of tape from the shaft, untangled it, took out the kinks and played it back. The tape did not break and the coating did not flake.

Boiling water had no effect on it nor did a sojourn in the freezer. We stretched a piece from 8 inches to 14 by grasping it firmly in both hands and pulling very hard. The tape did not break and the coating was as good as

S T A **F** K S T E D

Product: "Lifetime Tape".

Price: SMN-6P, 600 feet, \$5.25; SMN-12, 1200 feet, \$9.75; SMN-24P, 2400 feet on hub, \$16.95; on reel, \$19.80.

Manufacturer: Reeves Soundcraft Corporation, 10 E. 52nd Street, New York 22, N. Y.

ever, in fact it still played in the recorder. The point where the tape begins to stretch is past the break point of ordinary tape.

The great strength of the tape is due to the use of DuPont "Mylar" as a base. On this Reeves Soundcraft has coated its magnetic material in a new binder. Neither tape nor binder contains plasticizers so the tape will not change characteristics with the passage of time.

Its immunity to heat and cold and to changes in humidity will make for relaxed storage requirements, without special cans or boxes.

It is guaranteed by the manufacturer never to break, curl or flake under normal conditions of recording and playback.

Recording and playback characteristics were excellent on the test reel.

The tape, which carries a premium price, will find its greatest use in reels that must be preserved indefinitely and in broadcasting or research applications where tape stretch will throw timing off.

If the tape we tested is any criterion, and it was a reel pulled from stock, Reeves Soundcraft is never going to be called on their guarantee. The tape is top quality—and tough; a fine product.



Reeves "Lifetime" tape is difficult to break in the hands. If attempted, care must be taken to avoid cuts. Normal usage on a recorder could never break it.

SOUND EFFECT: WATER

by
Bart Pierson

TWERN'T a fit night out for man nor beast. The rain beat madly against the roof and the roar of the breaking surf as it crashed against the beach of No Trouble Atoll sounded like distant thunder.

Suddenly a shrill scream tore through the night. A shout for help. Homer, snug in his beachside cabin, sprang into action. He rushed to the water's edge and peered into the black night. A flash of lightning revealed the source of the cry. Offshore a head bobbed beyond the breakers.

"Fear not," called Homer, and taking off his shoes and his waterproof watch he plunged into the boiling surf.

How would you like to record that on your recorder?

First, you would need a wild and wooly script. If you can't dream one up yourself, just extend the opening given above. That's wild enough for anything. A party group or your own family can provide the actors. Then, of course, you'll need the sound effects. That's what this article is about, believe it or not.

First, let's take the matter of realistic rain. Oddly enough, so far as the microphone is concerned, a real rain isn't half so convincing as a handful of dried peas, or pea-beans (ask any Navy man) rolled inside a drum. An empty oatmeal box on an axle will do nicely. You can even create the effect, as shown below, by dumping the peas in a pan and rolling them around in front of the mike. This takes a steady hand to keep them moving at all times, otherwise the rain will be very spasmodic. For the wind, a whistling of air between your front teeth, close to the mike, will sound like quite a breeze on the tape.

The peas in the pan are better for the creation of the sound of surf than of rain. By tilting the pan first in one direction and then in another, the rolling beans sound just like the crash of waves on the beach. If you're skillful enough at pan tilting, try to keep a few peas always in motion to provide some continuity to the sound.

To make the sound of someone swimming, or apparently drowning, you've got to get real H₂O. A large bucketful will do, but a washtub full is even better. There's no sense restricting your talents as a sound effect man.

As this usually turns out to be a rather wet performance, a thick layer of newspaper should be put on the floor to catch the flying spray. Also, be careful not to souse the mike if you're carried away. Paddle the water vigorously with your hand to create the splashing sound.

This is one place where two mikes are better than one for while you're whipping up the sound, your actors should be emoting. If everyone tries to use the same mike, someone is going to get wet.

Hook up the two mikes to a mike mixer. These convenient gadgets can be purchased cheaply and are mighty handy. Usually they will accommodate up to three mikes and have one cord that plugs into the recorder. The more expensive units will also accommodate a phono input and all inputs may be varied to get the blending of sound that you want.

If you prefer "canned" sound effects to fresh, home-made ones, you can get a sound effects record or two that you can play on the record player while the actors give with the lines. It's a lot easier and the results are fine.



Above: the sound of splashing in water is made by doing just that. Right: beans or peas in a metal pan will sound like surf.



Tape Club News

RECORDING CLUBS BOON TO SHUT-INS

NOVEL NOTIFICATION CARD

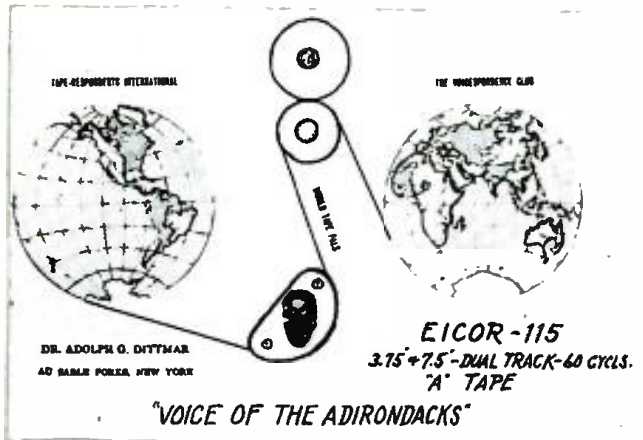

Dr. Adolph G. Dittmar, Au Sable Forks, New York, "The Voice of the Adirondacks," uses this novel photographic notification card. Photo cards are easy to make and others might like to try them.

TAPESPONDING NOT EXPENSIVE

From Tape Respondents International comes this bit which is worth repeating.

Ours is not an expensive hobby since a good home recorder costs no more than a good radio or TV set. As recording tape or wires may be used over and over (they last indefinitely) a large supply of either is not needed.

Talking letters may be mailed for a few cents, the same as ordinary letters. Even the small three inch reels can carry 2500 words or about as much as you could type (single space) on five pages of letter size paper."

All types of people are members of the club so it is easy to find someone with interests similar to your own. Tapesponding is just like chatting with a neighbor—except in this case the neighbor may be halfway around the earth.

SLICK TRICK

A member of the Voicesspondence Club who prefers to remain anonymous pulled the trick of the week recently.

He had been kept awake for weeks by the nocturnal bangings of a nearby auto-body repair shop. This noise was against the law but no one wanted to complain to the police.

Unable to stand the noise any longer, he took a recording of a terror stricken woman's scream which he had and played it full volume out the window with his recorder. Then he put the equipment away and went back to bed.

The scream alarmed the whole neighborhood and someone called the police. They naturally could find no foul play when they arrived but they did discover the shop in noisy operation so they arrested the proprietor and the night work was stopped.

NEW CLUB ADDED TO LIST

Global Recording Friends, with Alfred L. Sferra, D.D.S. as secretary is now a going club and accepting memberships. As yet its roster is small but is growing.

The club has several unusual features: it plans live meetings and discussions for members living in the New York, New Jersey and Connecticut areas.

Plans are also underway to set up a Teen-Age group within the club to be called "Junior Global Recording Friends." Teen agers interested in joining should write to Dr. Sferra and if enough interest is shown the group will be formulated.

The club also plans to publish a paper "World Tape News" which once a year will contain a complete financial report.

Membership inquiries should be addressed as shown in the box below.

ROSTER OF CLUBS

A letter or postcard addressed to the club of your choice will bring you full details regarding membership, dues, etc. A self addressed stamped envelope will be appreciated by the secretaries.

TAPE RESPONDENTS INTERNATIONAL

Fred Goetz, Secretary
P. O. Box 1404T, San Francisco, Cal.

THE VOICESPONDENCE CLUB

John M. Schirmer, Secretary
1614 N. Mango Ave., Chicago 39, Ill.

WORLD TAPE PALS

Harry Matthews, Secretary
P. O. Box 9211, Dallas, Texas

GLOBAL RECORDING FRIENDS

Alfred L. Sferra D.D.S., Secretary
125 Hamilton Street, Bound Brook, N. J.

VOICESPONDENCE MEMBER WITH MUSCULAR DYSTROPHY ENJOYS CONTACTS

One of the gratifying things about voicesspondence is the way it enables shut-ins and other handicapped people to have normal social contacts without even having to leave their rooms.

Earl Singleton, Jr., of Fort Worth, Texas, is such a person. Earl is a victim of muscular dystrophy (or "MD"), a "mystery disease" of doubtful origin and no cure that manifests itself by the wasting away of the muscles until the patient is no longer able to perform normal physical functions such as walking, standing, and the like. The course of the disease may run for many, many years, with the patient becoming very gradually more incapacitated.

Earl, as we said, has MD. He is able to handle his job as accountant with a large wholesale house with no trouble—except he is confined to his desk—but once he gets home of an evening he is not able or willing to go out again. It is here that voicesspondence enters the picture. Earl has several tape and wire recorders and by means of them he visits his many friends in all parts of the world. His deep Texas drawl and cheery good nature have made him known and loved everywhere his recordings go.

A coincidence of the type that has become frequent in voice spondence resulted when a new member of the Club, Harold Young of Johnstown, New York, making his first voicesspondence contact wrote Earl. After exchanging a tape they each were startled to discover that both were victims of MD! Harold is a cab radio dispatcher



MD victim Earl Singleton Voicessponds with friends.

and is confined to a wheel chair, and he, too, is now having new friends from far and near drop in to visit him via his recorder.

The Voicesspondence Club has quite a number of other handicapped people among its members, including a good many blind persons, each of whom can talk to friends via recorder as easily as anyone else.

SCHOOLS SWAP TAPES

"Tape Topics" the paper of World Tape Pals reveals an interesting exchange of tapes between the boys of Netherside Hall at Skipton, near Yorkshire, England and students of the John Henry Brown elementary school in Dallas, Texas. They find they have common interests in cowboy movies, football and folk music.

A pageant explaining American folk songs was presented by the 5th grades of the Dallas school. This was taped and sent to Frederick Redfern, master of the English school. In return, the English students gave the Dallas children an excellent insight into their school life and a vivid description of the countryside near the school.

Several misconceptions on both sides of the Atlantic were cleared up by the tape. One British boy said, "I used to think that Dallas was populated by bandits and red Indians but I have found myself to be wrong."

The Dallas group found the interest of the British children in bird watching to be strange to them.

MORE MILEAGE

Fred Goetz of Tape Respondents International suggests running 200 feet of tape on each 3" reel from a large 1200 foot reel. This will give you six 3" reels, which will enable you to get more words in per tape. There is no increase in postage.



Binaural Sound With Two Recorders

by Ronald Anderson

... for a real sound thrill try this with a friend

WHEN it comes to binaural recording on magnetic tape, two heads are better than one. In fact, they're essential. If you've listened longingly to binaural recordings with their amazing sensation of reality—but are stymied by the price tag on a binaural unit—there's still hope. While saving your shekels for a regular binaural tape recorder, you—as a tape recorder owner—can enjoy binaural recording right now.

The requirements are a dual track tape recorder with microphone and ordinary headphones, and a friend with similar equipment. Both recorders must play at the same speed, of course, and one must be equipped with Allen Shoup record and erase heads made by Shoup Engineering Co. Among the recorders using heads of this type are Pentron, DuKane, Tapemaster and some Crestwood models.

The key to binaural sound with the system described here lies in turning the pole pieces of one of the recorders upside down. Then by simply setting the two recorders

side by side and threading a single reel of tape through both machines, you can record on both tracks simultaneously.

Inverting the pole pieces on the one recorder takes less than 10 minutes and you don't have to be a mechanical genius, since the only tool needed is a screwdriver.

Although recorded binaural sound is not new, it has attracted widespread attention only since the development of magnetic tape, which makes binaural recording really practical and economical for the first time.

Normal human hearing is binaural—you hear through two ears. Because your ears are a few inches apart, each hears from a slightly different position and at a slightly different time and consequently gives depth and direction to the sound.

Normal monaural procedure is to record sound on one track at a time on the tape using one microphone. The sound is played back from one track and heard through

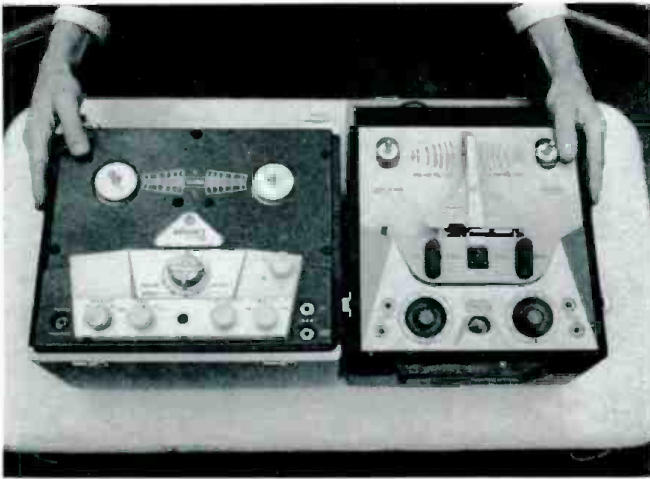

Above: Ekotape recorder, left, and Pentron, right, were used. Note that the Ekotape machine is set front to back so the tape moves from right to left in both machines and oxide side of tape contacts heads properly. Reference points should be marked on recorders so they can always be replaced exactly in same position. Upper right: to expose the head assembly, remove the two screws in the cover plate assembly. Upper center: a demagnetized screwdriver is used to remove head assembly as a unit. Do not remove heads separately. Lower center: close-up of head assembly shows erase head at right, record head at left. Note nickle-colored half of pole piece is at bottom in normal position. This is the Mu-metal part which is magnetic. Top half of pole piece is brass and is "dead" magnetically. Lower right: here pole pieces are being pulled out of slots with fingers and carefully re-inserted upside down. This must be done with caution to avoid bending or damaging pole pieces. Head assembly is then replaced in exact position. Trace around head assembly with pencil before removing it.

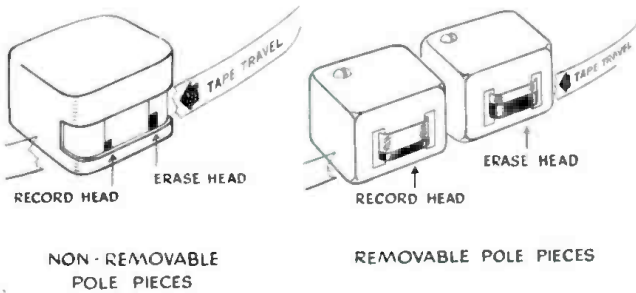
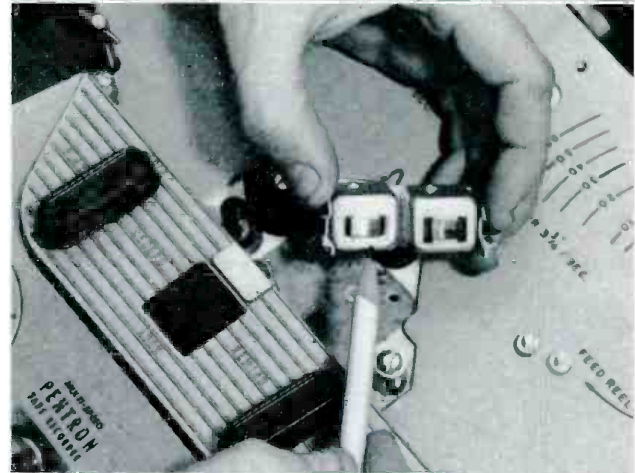
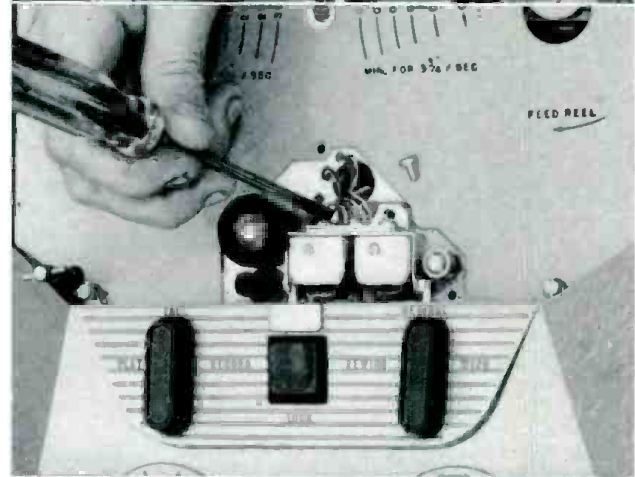
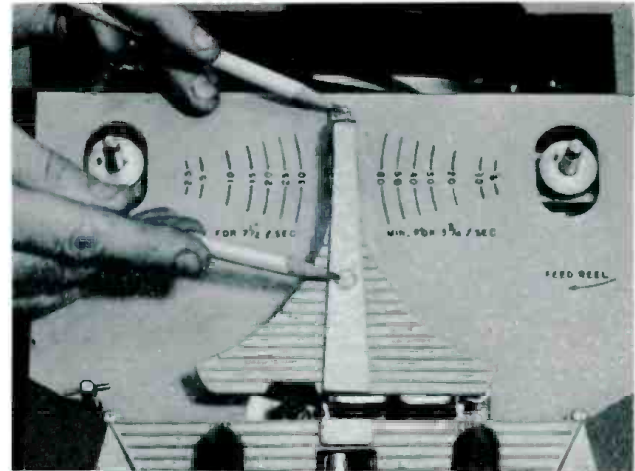

The sketch shows two types of heads used on home tape recorders. The head assembly at right has removable pole pieces necessary for binaural recording by the method described here.

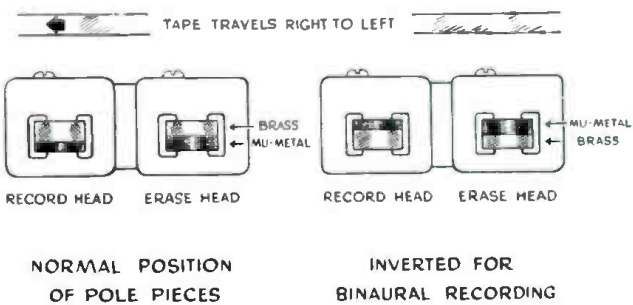

This shows relative positions of Mu-metal sections of record and erase heads before and after inverting. Modified Pentron can be used for regular monaural recording without changing pole pieces back but tapes recorded with inverted heads cannot be played back on any other machine.

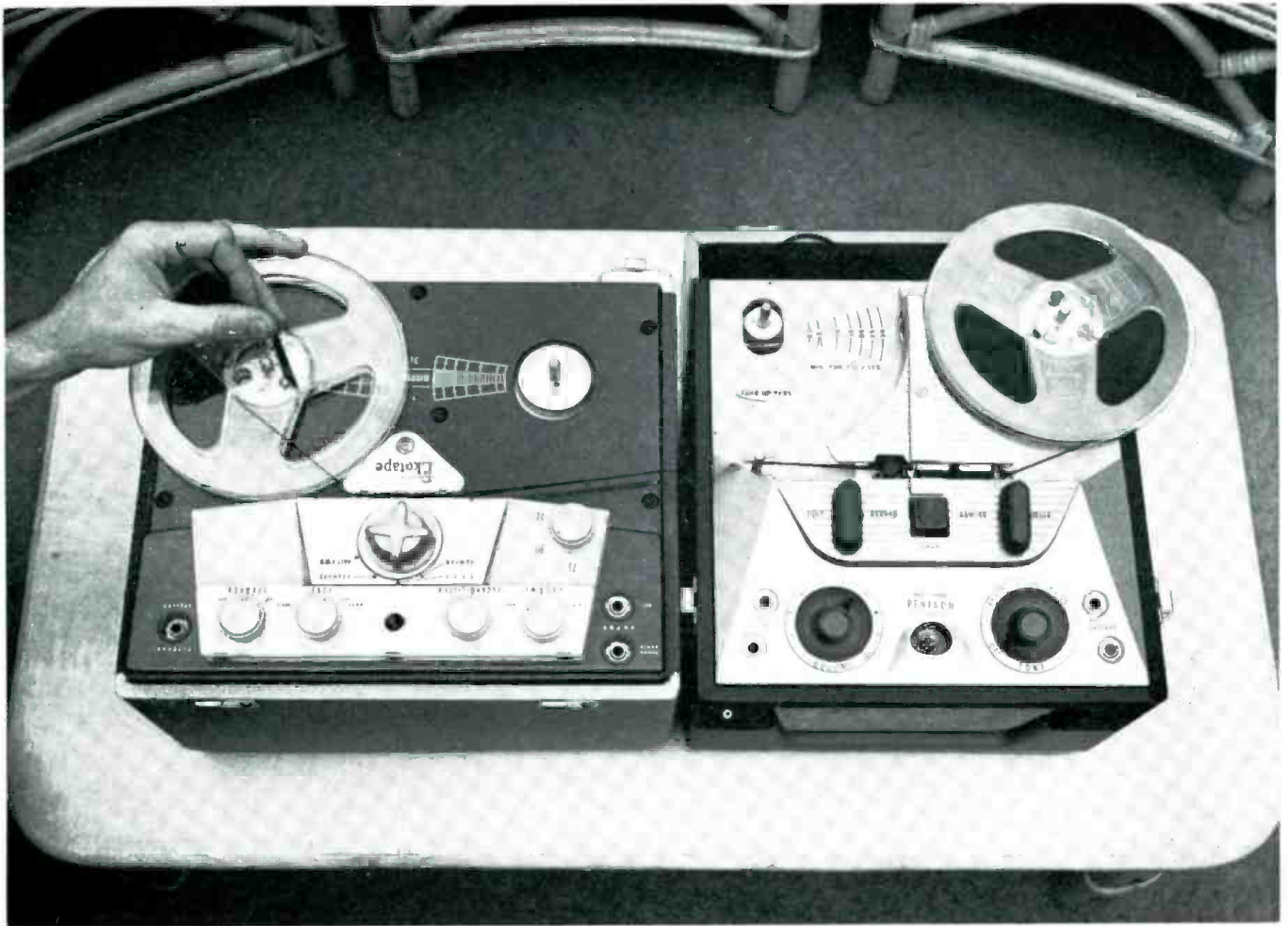

Above: picture shows how the reels are mounted on the recorders for binaural recording. The tape in this case travels from right to left and goes through the heads of both machines. Below: since the Ekotape is used to pull the tape through both machines, the pressure roller is removed from the Pentron by removing the screw that holds it in place. This allows the tape to pass freely over the Pentron capstan. Once the machines are aligned, reference marks should be placed on them so that they may be realigned easily.

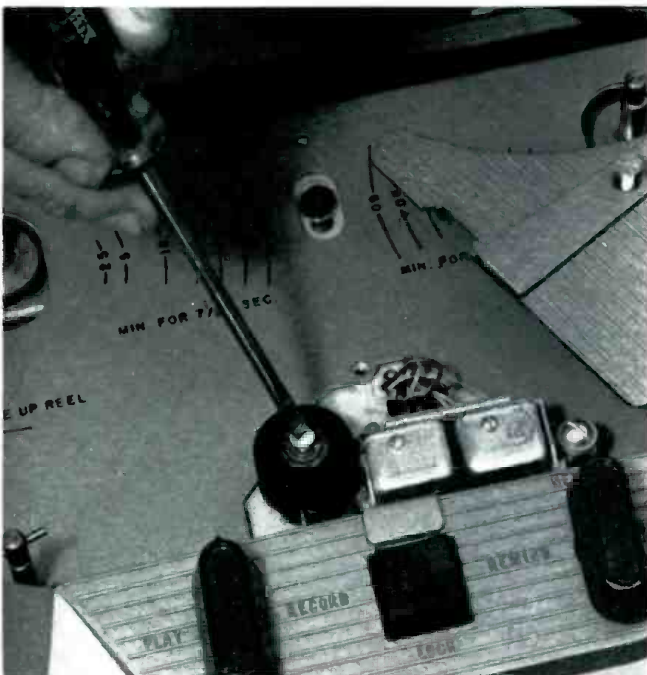

a single loudspeaker. Despite the fact that you're listening with both ears, the depth and direction of the original sound is missing.

Binaural recording on tape, on the other hand, consists of recording with two microphones on two separate tape tracks, and then playing back the sound from the two tracks through two speakers or sets of headphones.

Because each microphone picks up the original sound from a slightly different position one ear hears the sound picked up by one mike, while the other hears that picked up by the second. Consequently the depth and dimension—the realism—of the original sound is successfully recreated upon playback.

Some recorder owners have attempted binaural recording with two recorders used independently, but because it is impossible to maintain exact synchronization on playback, the method is unsuccessful.

Even using this method, it is next to impossible to maintain exact phasing, or synchronization of the two sound tracks, due to minute variations in positioning of the recorders, or stretching of the tape as a result of humidity changes. However, even if such factors do cause some phase loss, the binaural effect will still be present because of differences in volume of the two sound tracks. It's what Hollywood calls "poor man's binaural."

The problem in achieving binaural sound on home recorders is this: all dual track tape recorders are standardized so that machines on which the tape moves from left to right across the head record the top half of the tape. On machines on which the tape moves from right to left, the



For the first trial, place the microphones six or eight feet apart. The distance of the mikes should be varied to obtain the best results for various types of binaural recording. The volume settings should be equal. For a test, record as you walk about the room.

bottom half of the tape is recorded. This applies only to machines using "A" wind tape with the oxide wound "in" on the reel. The situation is exactly reversed with "B" wind machines.

First step is to place the two recorders side by side so reels turn in the same direction. See picture page 33.

Thread the tape through both heads, placing the reel of tape on the feed reel side of one recorder and the empty reel on the take-up side of the second recorder. This makes it possible to visualize the problem. It is apparent that whatever is recorded by the first machine will be erased by the second machine with the pole pieces in their normal position.

Since the Pentron recorder appeared to be the easiest to work with, it was chosen, together with an Ekotape recorder, which—like the Pentron—moves the tape from right to left when positioned as shown in the picture.

Because the Pentron has removeable pole pieces in its recording and erase heads, all changes are made on it.

First step, is to remove the cover plate of the Pentron to get at the head mechanism. This is done by removing the two screws shown in the picture.

Next remove the head assembly, again by loosening two screws, as shown in the next picture. This makes it possible to remove both the record and erase heads as a unit, keeping them in their exact relative position.

Trace around the head mounting plate with a pencil

before loosening the screws in order to insure that the head assembly is put back in exactly the same position later.

A look at the head assembly, shows the erase head on the right and the record head on the left. Note that each head has a "U" shaped pole piece with the ends of the "U" slipped into a pair of slots, but which can be pulled out if carefully done.

Note also that each pole piece is made of two kinds of metal—a nickel-colored metal and partly of brass. The nickel-colored metal is Mu-metal and is the material of which most recording heads are made. Thus the nickel-colored portion of the head is the "live" magnetic part, while the brass portion is "dead" magnetically. Consequently the nickel-colored Mu-metal area on the bottom half of the right hand pole piece erases a path down half the width of the tape. The slightly narrower Mu-metal area on the left-hand pole piece does the recording. The brass area merely supports the other half of the tape.

Although these pole pieces may be lightly cemented in place, it should be possible to remove them using the fingers as shown. If this fails, pad the blade of a screwdriver (be certain it is not magnetized) and gently ease them out, being exceedingly careful not to bend or damage them.

As each pole piece is removed, simply turn it upside down and slip it back into its slots. Now instead of the Mu-metal area being on the bottom, it will be on the top.

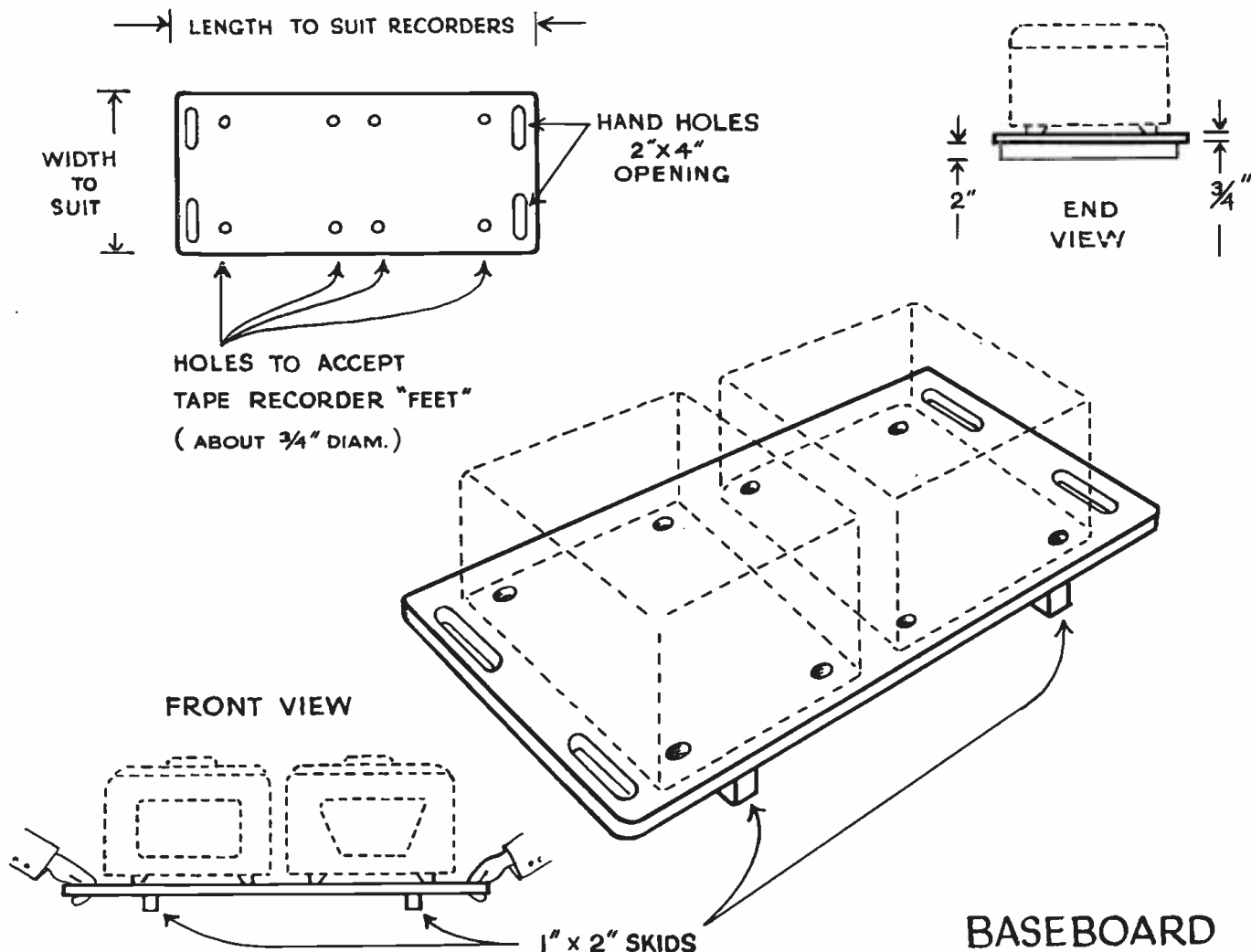

The sketch shows a type of baseboard that easily can be made from $\frac{3}{4}$ -inch plywood to insure exact placement of recorders relative to each other for recording and playback. It is absolutely essential that recorders always be placed in exactly the same relative positions.

Since the machine which feeds the tape is not required to do any pulling, it is advisable to remove the pressure roller as in the picture. This allows the tape to pass by the capstan freely.

Now replace the cover plate and thread the tape on the machines, as shown, and you're ready to start.

Plug each microphone into its respective recorder and place the mikes six or eight feet apart for the first trial, as in the picture on page 35. Turn on each recorder and adjust volume so that the light flashes on each machine about equally. Be sure both recorders are set for operation at the same speed—either $3\frac{3}{4}$ inches per second or $7\frac{1}{2}$ i.p.s. Then put each machine in "record" position and start recording.

As a trial, walk about the room as you talk in a fairly loud voice, calling out your position as to "left" or "right" of the machines. Continue talking as you walk straight across in front of the recorders. Then try carrying on a conversation with your friend from opposite sides of the room. A good demonstration is for two persons several feet apart

to clap hands alternately. The effect when heard through the headphones is very realistic.

To play back your first binaural recording, stop the recorders and rewind the tape. Remove the microphone plugs and plug in the headphones, as in normal operation.



This shows how an Ampro and a DuKane recorder may be used for binaural recording. DuKane also has Shoup heads which may be inverted. A half twist in the tape is necessary with these machines.

However to listen binaurally, your right ear must hear the recording on one track while the left ear must listen to the other track. To achieve this, simply interchange one ear-phone from each set. This leaves little leeway because of the short wires used on the phones, but listening with heads together can be even more interesting especially if your friend is a member of the opposite sex.

A single set of headphones can be used if a separate wire and jack is attached to each ear-phone so that each recorder feeds into a separate ear-phone.

Then with the recorders on "play" you'll get your first taste of home-made binaural and if you've done everything along the way correctly, it should be terrific. It should not be necessary to readjust the volume on either machine, although—since they are not matched—some volume adjustment may be required to obtain top effect. Naturally the recorders must be in *exactly* the same position for playback as record so that the tape goes through each head at the proper relative interval. Not even half an inch off!

You'll find plenty of sounds to record binaurally, some of which are more directional, and thus more effective, than others. A ping-pong game is an excellent demonstration, or a toy train (or a real one, for that matter) rounding the bend.

Binaural recordings of musicians are highly rewarding and will provide more "concert hall realism" on your home binaural recording unit than on any type of monaural machine.

If you plan on making recordings "on location" you'll probably want to make a baseboard of some type to insure exact placement of the recorders in their proper relative positions, and also to facilitate moving the two recorders about the room as a unit.

One method is to make such a baseboard out of $\frac{3}{4}$ -inch plywood with hand-holds on each end and with holes drilled in it to locate the recorder "feet." This is shown in the drawing. Do not drill the holes clear through the baseboard, however, since many recorders depend on air circulation under the recorder for cooling.

Using recorders other than the Pentron and Ekotape used to illustrate this article, certain changes must be made because of variations in recorder design, and the direction



The results are worth the effort! Binaural recording brings a sound realism that must be heard to be appreciated. One earphone from each headset is interchanged so each ear hears a separate channel.

of tape travel. However, the basic principles still apply and once you understand them, you can improvise for your particular equipment.

For example, the picture on page 36 shows how Ampro and DuKane recorders can be used. Note that the tape travels from left to right as it normally does on the Ampro but that since the DuKane operates from right to left, a half twist is put in the tape and the recorders set front to back to make everything work out right.

NON-SKID TIRE² FOR MICROPHONES by Karl A. Barleben

Some of the less-expensive and smaller ceramic microphones as furnished with tape recorders like the Crescent Compact and the Telectro-Tape are perfectly round, small and (because of the plastic-material housing) extremely light in weight. So light, in fact, that even the stiffness of the cord easily causes them to skip or slide off any smooth surfaces, as a table, upon which they may have been placed horizontally for recording purposes. This is always annoying to the recordist and frequently dangerous to the microphone through the possibility of dropping to the floor accidentally.

Casting about for some simple means of providing a non-skid device for microphones of this type, I hit upon the idea of cementing a flat strip of black rubber about $\frac{1}{4}$ -inch thick and 1-inch wide, and having a "lip" or bulge running along one side, completely and securely around the circumference of the microphones with "household" or "model airplane" cement. In doing this, I took care to position the rubber strip around the microphone in such a manner that the "lip" protruded or extended slightly beyond the outer limits of the rear of the microphone housing, thus assuring that, when placed flat, this lip would contact the supporting surface and prevent the microphone from slipping away or being shifted in position. The idea works nicely!

By the same token, when the microphone is hand-held . . . as it often is . . . this rubber stripping offers a more secure and comfortable grip. Thus, with the aid of this idea, or any reasonable facsimile thereof, small, lightweight microphones can be made to "stay put" where placed on a smooth surface, and more comfortable to hand-hold.

The larger, heavier microphones in cast-metal housings, too, are benefited by this treatment. In any case, this idea offers several excellent and important functional utilities and affords the microphone in general additional protection from damage.



How to Check Your Recorder

by

Harold D. Weiler

Part III of a series by the author of High Fidelity Simplified

. . . new test tape may be used to check recorder faults including head alignment, level, flutter and wow.

PREVIOUS articles explained the requirements for high-fidelity recording and reproduction of speech and music. If the original high quality of the recordings obtained from equipment of this type is to be sustained, proper maintenance is also an important requirement. It has been a constant source of amazement to the writer and a tribute to American manufacturing ability that the average tape recorder operates as well as it does, when we consider the small amount of attention it receives.

Any device, be it mechanical, electrical or electronic re-

quires some maintenance. Mechanical devices usually require more than the other two. A tape recorder is a combination of all three devices and, in addition, has a rather complicated mechanical section consisting of motors, guide pulleys, clutches, capstans and reels. All of these moving parts are subject to wear and slight misadjustment which results in gradual deterioration of the quality and, in some cases, distortion. However proper maintenance can reduce these effects to a negligible factor and greatly increase the useful life of the recorder.

One of the most common tape recorder complaints is that the quality of the tapes originally made on the instrument has deteriorated and when they are reproduced at a later date, sound muddly, distorted and lack brilliance. Usually the owner blames the tape manufacturer and changes his brand. Manufacturers of pre-recorded tape are also accused of releasing poor tapes, since the same recorder will also reproduce these poorly. The fault lies not with the manufacturer, in either case, but with the recorder or more properly, the owner.

When consistently good reproduction is required the playback head slit or gap must always be perpendicular to the edge of the tape as illustrated in Figure 1. When the recorder was new, the head was undoubtedly in this position but due to jars, bumps and the constant vibration created by the speaker and motor, the head may have shifted as shown in Figures 2 and 3. This misalignment usually results in the effects previously mentioned, poor reproduction with greatly reduced high frequency response. The greater the

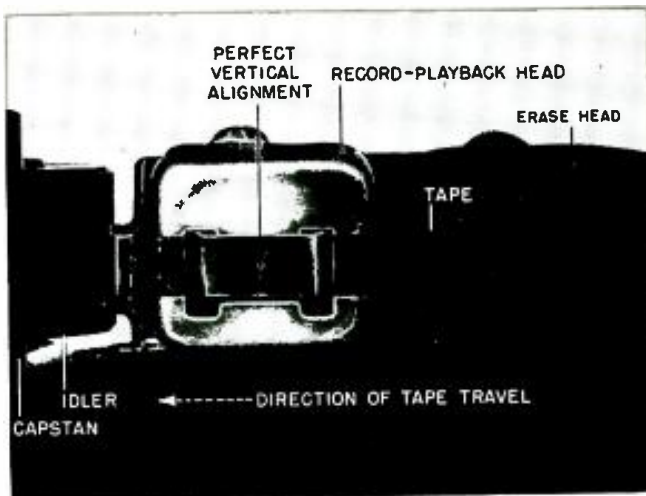

Figure 1: When your recorder left the factory its head was in perfect alignment and would playback or record with maximum fidelity.

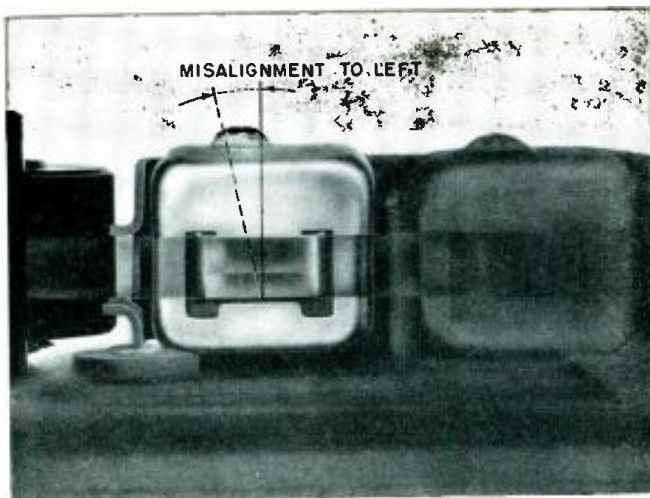

Figure 2: due to bumps or jars, head may become misaligned.

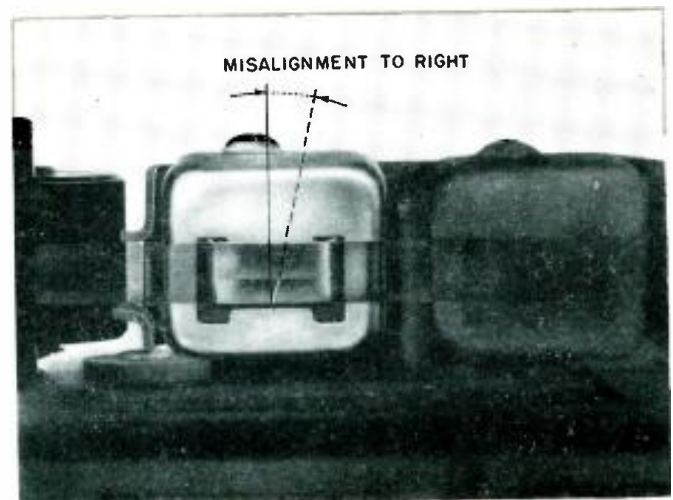

Figure 3: head shift, either to left or right will decrease response.

The Tape That Mirrors the Original Sound

SOUND RECORDING



irish

BRAND

GREEN BAND Professional



THE FINEST TAPE YOUR RECORDER CAN USE

Just as the reflection of a perfect mirror is faithful to the original image, in every detail, so too does IRISH Green Band RECORD, RETAIN and REPRODUCE the original sound with flawless fidelity.

This can be confirmed by tests. Instruments will reveal that IRISH Green Band offers lower noise level, uniform sensitivity, minimum amplitude variation, less distortion.

But instrument tests are only the landmarks

of good design and production. The final proof is in the hearing. Therefore, to know and appreciate the quality of IRISH Green Band Tape, it must be used, listened to, and compared with other tapes on the same recorder.

You will find that the only limitation to IRISH Green Band quality is the limitation of the tape recorder itself: it is the finest tape your recorder can use.

irish
BRAND
GREEN BAND
Professional

is fast becoming the choice of audio engineers in broadcast stations, recording studios and wherever sound quality is of paramount importance.

1200 feet on plastic reel..... \$3.30 users net

2400 feet on metal reel..... 7.71 users net

One day you will surely use IRISH . . . so write today for free test sample reel.



irish BROWN BAND for Popular Priced Recorders:

IRISH Brown Band, expressly designed for home and office recorders. Reproduces with true fidelity the frequency range from 100 to 8000 cycles. A high quality, plastic base tape for the price of ordinary paper tape!

1200 feet, plastic base, on plastic reel..... \$2.50 users net

At all leading radio parts distributors

ORRADIO INDUSTRIES, INC.

OPELIKA 4, ALABAMA

World's Largest Exclusive Magnetic Tape Manufacturer
EXPORT DIVISION: Morhan Exporting Corp., New York, N. Y.

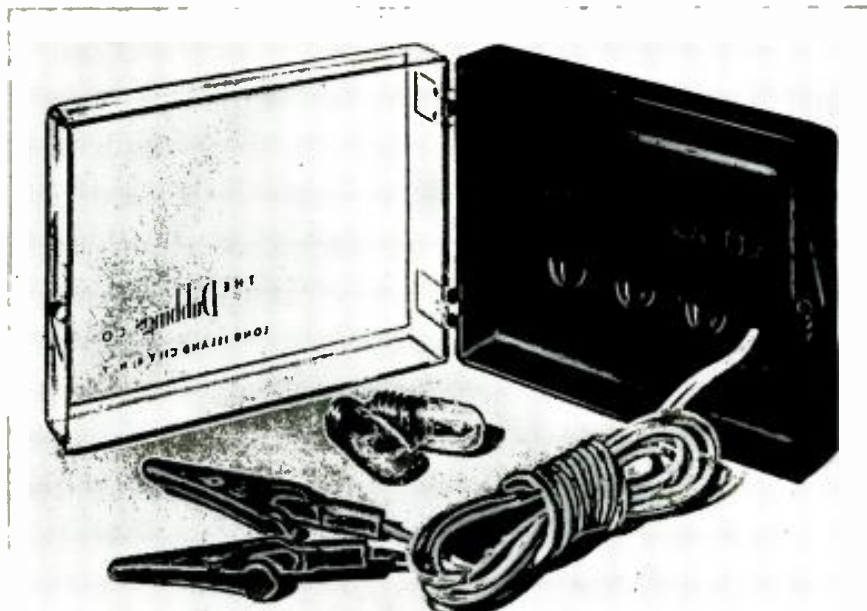

Figure 4: this is the test level indicator used with the new tape. With the volume control at a low setting, the recorder head is adjusted to get maximum brilliancy in the indicator lights.

degree of misalignment, the poorer the high frequency response.

Until recently realignment was a rather complicated business and required equipment found only in laboratories. However, the advent of new devices, such as the Dubbings Test Tape and associated equipment such as the inexpensive test level indicator shown in Figure 4 have made this operation comparatively simple.

The test tape is run through the recorder until the announcement of the alignment section is reached. The test level indicator is then connected across the speaker terminals or into the output jack of the recorder. The playback volume control should be kept at the minimum position and gradually increased until the bulbs marked minus 3 and zero light dimly. At this point, it is advisable to rewind the test tape to the beginning of the alignment signal, in this manner, providing full time for the alignment adjustment. The playback

head is then adjusted, in accordance with the detailed instructions furnished, until the bulb marked plus 3 lights. The amount of improvement and consequently the change in light intensity is, of course, dependent upon the degree of misalignment of the head. In some cases the user may not be able to light the plus 3 bulb at this volume control setting, but will find that manipulation of the head does increase the intensity of the minus 3 and zero bulbs which is indicative of increased signal. The goal should be to obtain the maximum amount of light with a minimum volume control setting. This simple procedure results in complete head realignment of the average recorder, since the same head is usually used for both record and playback functions.

This alignment factor is quite important when the owner of a tape recorder wishes to exchange tape with friends, use the superb prerecorded tapes now available, or is acquiring a collection of tapes. Periodic checking with a test tape will insure consistently good recording and reproduction.

Another common cause of reduced high frequency response and distortion is even more simple to cure and is due primarily to airborne dust and the microscopic particles worn from the tape which accumulate on the record-playback head. These tape particles and the dust accumulate on the head and in the gap shown in Figure 1 and prevent the close contact between the head and the tape which is required for optimum results. Any accumulation can be easily removed with a Q-Tip, pipe cleaner or cotton swab saturated with carbon tetrachloride or alcohol.

Worn tape pressure pads may also be responsible for reduced high frequency response and distortion, since they permit poor contact between the tape and the head. The majority of modern tape recorders have some means of adjusting these pads to compensate for wear, however care should be used, if they are dusted too tightly the tape movement may be restricted. A convenient means of checking the tape speed is also included on the Dubbings Test Tape. Before any adjustments are made, the original speed of the instrument should be checked, as any changes which affect the speed will also affect the pitch of recording made previously.

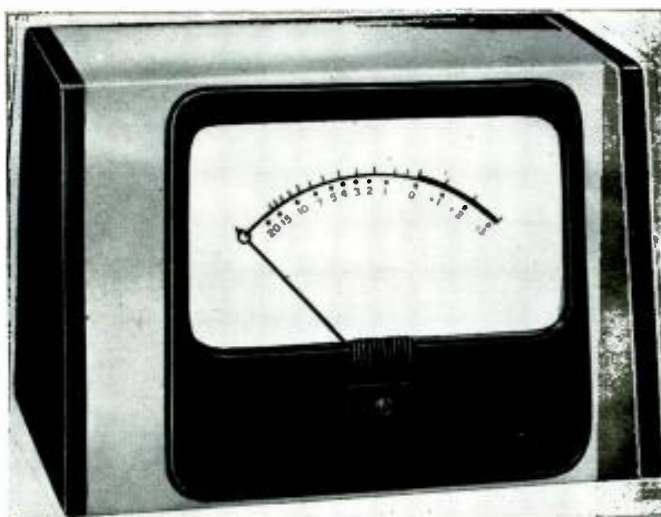

Fig. 5: the Sonofax V.U. meter which indicates recording level and is made in a number of models for different recorders. A meter such as this makes it easy to determine the correct recording level when used in conjunction with the test tape.

The procedure is quite simple, the test tape is inserted in the instrument and run for 1 minute. At this point, an announcement is heard and a tone starts the timing run, exactly 5 minutes later another announcement and tone is heard. The third and last announcement and tone of the timing run occurs exactly 10 minutes after the start. Once the timing of the original speed is checked and recorded the pressure pads mentioned previously may be adjusted. After adjustment the tape speed is again checked. This adjustment should not result in any appreciable variation from the original speed of the tape past the head, for the reason previously mentioned. The signals on the tape are extremely accurate.

The next important problem encountered in maintenance is wow and flutter. The terms wow and flutter, as previously explained in Part 2 of this series, are used to describe any variation in the speed of the tape as it moves past the head (either record or reproduce). These variations are indicative of the mechanical condition of the recorder. The term wow describes any variation which occur at a relatively low rate of speed (not more than 10 times per second). The term flutter is used to describe the same condition at a higher rate of speed (above 10 times per second).

Wow and flutter interest us since they cause a change in the pitch of a musical reproduction. This change is particularly noticeable in the reproduction of any high pitched instrument such as a clarinet or violin. Since the human ear is extremely sensitive to any change in pitch during a sustained note, any small variation can be quickly noticed and is objectionable.

The use of the 3000 C.P.S. wow and flutter signal on the test tape makes the tracing of these forms of distortion fairly simple, since against its background they become quite apparent. Speed variations are always due to some specific elements in a recorder's moving system. These variations usually have a constant rhythm which can be counted. By checking the number of revolutions per minute, made by the various elements in the moving system, such as the capstan, pressure idlers, motor pulleys, etc., the source of the wow or flutter can usually be found quite quickly. Common sources of wow are, uneven pressure on the tape pressure pads, oil or grease on the rubber idler wheels or capstan, warped reels, etc. The offending member should be cleaned with carbon tetrachloride when it is metal, or alcohol used sparingly if it is rubber. A rubber wheel that has developed a flat should be replaced.

One of the most important requirements for high quality recording lies not in the recorder itself but with the operator.

Most users do not record at the proper level. There is a maximum recording level which represents the highest amount of signal that can be put on tape without obtaining serious distortion. There is also a lower limit which is the minimum recording level, since below this level the recording may be obscured by background noise and hum.

Today practically all recorders have some means of indicating the intensity of the sound being recorded, it is usually a neon lamp or an electronic eye. Many of these volume indicating devices function on both record and playback positions. With these recorders the test tape can be used to obtain a positive indication of the maximum level which can be used without obtaining serious distortion, and as a means of calibrating the recording volume control. Since overloading a tape through the use of too high a recording level is responsible for more poor recording than all other factors combined, this particular section of the test tape is extremely important to the average user.

While on the subject of recording levels and indicating devices we might mention the new Sonafax U.V. Level Indicator, the meter of which is illustrated in Figure 5. When a number of people speak into a microphone at different volume levels or music with its constantly varying levels is recorded, overloading the tape, as previously explained, is quite common. Monitoring the tape with the average indicator is difficult since its variations are small and quite rapid.

Recording studios and broadcast stations use a V.U. indicator for this purpose. Unfortunately, up until now, none was available to the home user which could be easily connected and was calibrated for the individual recorder. Sonafax has solved this problem by providing different models for the various recorders on the market.

From this series of articles we have found that the quality of a tape recording is dependent upon:

1. The quality of the equipment used.
2. The proper maintenance of this equipment.
3. The knowledge of the operator.

Excellent recordings can be made with inexpensive equipment, just as superb photographs can be made with an inexpensive camera. However the operator must compensate for his equipment with knowledge and "tricks of the trade." The writer had heard many superb recordings made by amateurs with inexpensive equipment. In all cases, however, the recordist had spent the time necessary to acquire a thorough knowledge of his equipment and the field in general.

RECORDER MAKES EFFICIENT PHOTO TIMER

I've found that my tape recorder can be used very efficiently as a film developing timer when tray developing film in the darkroom.

First, the "time" is recorded by voice on the tape by noting the proper time from a clock. Spoken warning as to when the developing time is about to begin and end is useful in giving the photographer a chance to start gathering his negatives in the tray, ready to put them quickly in the stop bath when the developing time is up. Another time signal may be used to advise when the films should be shifted into the fixer.

Also, cut film and film pack negatives can be simultaneously developed to different developing times by recording the lengths of time beforehand. Generally, film pack negatives must be developed slightly longer than cut films. The pack negatives are much thinner, thus can easily be identified in the dark and separated from the stiffer, thicker cut films.

The tape, of course, can be used over and over and soothing music (for the photographer's ruffled nerves) can be recorded between the voice signals.

If desired you can put a time signal on the tape every minute.—Clarence Leino.



OFF THE TAPE

If, like the Chinese, we named the years for things, such as the Year of the Dragon, we would say that this is the Year of the Tape Recorder.

More and more people are buying these clever electronic servants and as of now there are about a half-dozen firms issuing musical and instructional tapes. These will further extend the enjoyment and pleasure of tape recorder owners.

Society of Music Enthusiasts Ends Connection with Hi-Fi Magazine.

The Society of Music Enthusiasts, now grown to an international organization with chapters in many cities has severed its connection with Hi-Fi magazine under whose wing it began life.

It now has its own charter as a non-profit organization under the laws of the State of New York and is completely on its own as a separate and distinct organization.

Lisbeth Weigel, Executive Secretary, is handling the club's affairs from the temporary headquarters in the Beverly Hotel, 125

East 50th Street, New York 22, N. Y. Those desiring to join the organization which is devoted to "helping the music lover in his quest for better understanding and achievement in music and to provide him with a means for sharing his pleasure and knowledge with others," should write to Miss Weigle.

The Society publishes a very attractive news bulletin and has a lapel pin which members may wear. Dues are nominal.

The Winner

Ken Maxwell, of Long View, Texas is the winner of the \$100 Prize in our recent word contest. Runners-up, who will each receive a one year subscription to Tape Recording are Miles J. Shatz, St. Paul, Minn., J. William Fredrickson, Chicago, Ill., V. R. Hein, Rockford, Ill., William Walsh, San Francisco, Calif., J. N. Stonesifer, Washington, D. C., Wolf Younin, Bronx, N. Y., and Harris A. Solomon, Syracuse, N. Y.

Six hundred entries were received and only one suggested "Tapeworm" as a name for a person who does tape recording.



... Officer Hurkes and recorder

Tape has taken over the job of educating Chicago citizens in safety. Safety messages are taped by members of Chicago's safety education unit and are played to the public from the white safety car which parks in the Loop district. An Ampro recorder is hooked to the speakers on the roof of the car.

More than 125 slogan type messages are flashed each hour from the tape which is played over and over again in the course of a day.

SHOP OR SWAP

Advertising in this section is open to both amateur and commercial ads. TAPE RECORDING does not guarantee any offer advertised in this column and all swaps, etc. are strictly between individuals.

RATES: Commercial ads, \$.30 per word. Individual ads, non-commercial, \$.05 a word.

Remittances in full should accompany copy. Ads will be inserted in next available issue. Please print or type your copy to avoid error. Address ads to: Swap or Shop, Tape Recording Magazine, Severna Park, Md.

FOR SALE: Thordarson Dual Tone Control, new, \$3.00; UTC-V1-C15 Variable Inductor, like new, \$7.50; G.E.-UPA-004 Tone Arm, like new, with used cartridge, \$3.00; Astatic E4P Record Equalizer, used, \$1.25; Astatic 400 Transcription Tone Arm and G.E. Triple Play Cartridge, needle used only 8 hours, \$12.50; Westinghouse 3" Square Meter, 0 to 500 volts, new \$7.00; Marrion 3" Square Meter 0 to 250 Ma., new \$7.00; Triplet 3" Square Meters, 0 to 150 Ma., new, \$5.00. Paul W. Curtis, Box 266, Enterprise, Oregon.

FOR SALE: Revere TR-800 with radio, cost \$277.50. Excellent Condition, \$175. Inspect at Express office. Request sample tape or particulars. Stone, Lunenburg 5, Mass.

FOR SALE: "Movie-Sound-8," 8 mm Magnetic Recording Projector, brand new. Lists \$399.—sell for \$275. Also Wilson "Synchronometer" automatic synchronizer for 8 mm film and tape. Cost \$115.—sell for \$60. Reech, 1616 E. 86 Street, Cleveland 6, Ohio.

FOR SALE: Slightly used portable, battery operated, spring motor, Model 610-D MAGNEMITE Tape Recorder. Price \$225. Cost \$325. Russel Ain, Fairfield, Iowa.

SUBSCRIBE TODAY!

Magnetic Film and TAPE RECORDING is the only magazine of its kind published. It is edited to show you how to get the most fun, practical use and personal profit from your tape recorder. Written so that anyone can understand it, it nevertheless is packed full of ideas and facts of value to amateur and professional alike. Each issue is full of how-to-do-it information on personal, business, educational and professional sound recording—prepared by men who know from personal experience what they are talking about. It's YOUR MAGAZINE—edited to help YOU enjoy this fascinating new world of sound.

USE HANDY COUPON BELOW

TAPE RECORDING

Severna Park, Md.

Please enter my subscription for one year (six issues). I enclose \$2.00 Bill me

Name

Address

City Zone

State

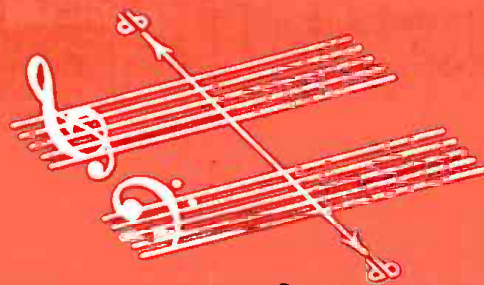

octaves and octaves of
distortionless, silky, new
decibels over the entire
audio spectrum

INSTALL



DYNAMŪ magnetronics

RECORD • PLAYBACK • ERASE HEADS

ON YOUR TAPE RECORDER

SEE AND HEAR
THEM NOW!
AT YOUR
TAPE
RECORDER
DEALER

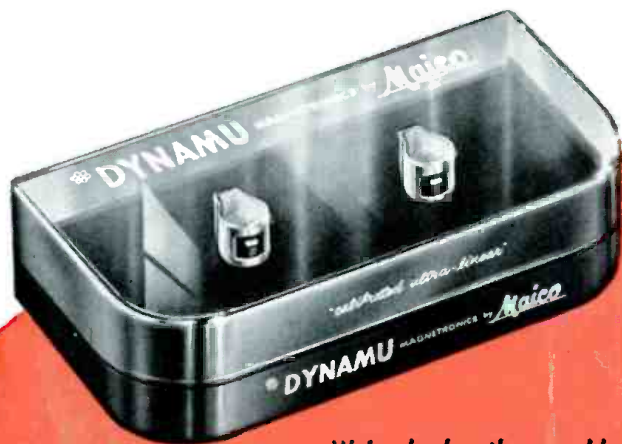

- Increased Dynamic Range
- Increased Fidelity
- Increased Sensitivity
- Increased Frequency Range
- Increased Signal-to-Noise Ratio

We've broken the sound barrier for tape!

For the first time, exciting new **ULTRA-LINEAR, HIGH-FIDELITY** performance! A wedding of the sciences of magnetics, electronics and optics developed **DYNAMŪ magnetronics** . . . to make your treasured tapes play better and your new tapes . . . superlative!

The **DYNAMŪ Calibrated Ultra-Linear series** provides 20-20,000 cycles at 7.5" with nominal equalization. The **DYNAMŪ High-Fidelity series** provides 50-15,000 cycles at 7.5" with nominal equalization.

DYNAMŪ magnetronics are available for installation on all leading recorders.

**Patents applied for*



You'll find the answers about immediate installation on your equipment in "DYNAMŪ and you!" Free at your tape recorder dealer.

DYNAMŪ MAGNETRONICS CORPORATION, A Division of The



Co., Inc., Maico Bldg., Minneapolis, Minn.



Captured...

Every note captured perfectly.

Every tone taped right...

the first time. That's why

more recording engineers use

"Scotch" Brand Magnetic Tape

than all other brands combined.

That's why you should use it, too.

...with **SCOTCH** Magnetic Tape



The term "Scotch" and the plaid design are registered trademarks of Minnesota Mining and Manufacturing Co., St. Paul 6, Minnesota. General Export: 122 E. 42nd St., New York 17, N.Y. In Canada: London, Ont., Can.



Listen to ARTHUR GODFREY TIME Daytime Program, CBS Radio-TV